



THE ISLANDS COMMUNITY ASSOCIATION

ARCHITECTURAL GUIDELINES RULES AND REGULATIONS

Revised
July 2023

The Islands Onsite Office
825 South Islands Drive West
Gilbert, Arizona 85233
Telephone: 480-545-7740
www.islandscommunity.org

THE ISLANDS COMMUNITY ASSOCIATION HOMEOWNER HANDBOOK ARCHITECTURAL GUIDELINES - RULES AND REGULATIONS

TABLE OF CONTENTS

WELCOME LETTER FROM THE BOARD OF DIRECTORS

ARCHITECTURAL REVIEW COMMITTEE (ARC) PROCEDURES

- Architectural Requests
- ARC Forms
- ARC Meetings
- ARC Approvals and Deadlines
- ARC Decisions
- Right to Appeal

RESIDENT COMMUNITY USE

- Community Park Rules and Regulations
- Community Lake Use Rules and Regulations – Swimming, Fishing, Boating

ARCHITECTURAL GUIDELINES - RULES AND REGULATIONS

1. Animals/Pets
2. Antennas, Satellite Dishes, Internet Access
3. Awnings, Retractable Awnings, Roll Shades (semi-permanent structures)
4. Basketball Hoops
5. Clothes Lines
6. Driveways and Extensions
7. Dumpsters, Portable Temporary Storage Units, Porta-Pottys
8. Fire Pits, Kivas, BBQ Pits (outdoor kitchens)
9. Flags and Flag Poles
10. Garbage/Trash
11. Gates
12. Gutters and Downspouts
13. Holiday Decorations
14. Landscape Artificial Turf
15. Landscape Enhancements/décor
16. Landscape (front yard)
17. Leasing of Homes
18. Lighting
19. Mailboxes
20. Main Residential Structures (new construction and rebuilds)
21. Outdoor Speakers/Television
22. Paint
23. Patio Covers (permanently attached to the house)
24. Play Equipment, Swing Sets, Trampolines
25. Pools/Spas
26. Roofs

27. Screen Doors and Security Doors
28. Screened Patios (porches)
29. Security Cameras & Security Lighting
30. Signage
31. Solar Energy Devices (including solar panels)
32. Storage Sheds (prefabricated or manufactured)
33. Structures, such as Shade Structures, Pergolas, Ramadas, Gazebos, Sail Shades or other similar structures (prefabricated, manufactured, or temporary)
34. Structures, such as Storage Sheds, Guest Houses, Ramadas, Gazebos, Pergolas or other similar structures (permanent)
35. Tennis/Sport Courts
36. Walkways
37. Walls and Fences
38. Windows
39. Wind Energy Devices

LAKEFRONT ARC GUIDELINES - RULES AND REGULATIONS

40. Lakefront Ownership
41. Lakefront Docks
42. Lakefront Easement
43. Lakefront Enhancements/Décor
44. Lakefront Landscaping
45. Lakefront Lighting
46. Lakefront Fencing
47. Lakefront Shade Structures (prefabricated or manufactured)
48. Lakefront Walls

COMMERCIAL ARC GUIDELINES - RULES AND REGULATIONS

TOWN OF GILBERT CODE & RULES

EXHIBIT 1 Dock Concept A

EXHIBIT 2 Dock Concept B

EXHIBIT 3 Dock Installation/Easement

EXHIBIT 4 View Fence & Support Near Lake Wall

EXHIBIT 5 Architectural Submittal Form

EXHIBIT 6 Paint Submittal Form & List of Pre-Approved Colors

EXHIBIT 7 Solar Guidelines and Form

EXHIBIT 8 Islands Board of Directors Resolution Violation and Enforcement Policy

WELCOME LETTER

Welcome to The Islands, one of the finest master planned communities in the East Valley! Our premier lake community is built on a foundation of strong social and business relationships. Layered into this foundation is a community of residents who value neighborly consideration, friendship, and kindness. The Islands Residents are proud of our lakes and neighborhoods. We are excited to welcome you to the family!

As a property owner in The Islands, you are automatically a member of The Islands Community Association. The Association is incorporated for the purpose of preserving and enhancing the value of the homes, as well as the amenities of The Islands.

It is the commitment and responsibility of The Islands Community Association and each individual property owner to preserve the quality of the community's lifestyle and to appropriately preserve the general architectural aesthetic and theme of residential, commercial, and common areas throughout The Islands so as to sustain the particular character of our neighborhoods and of our community generally.

The Islands Community Association Architectural Guidelines is a "living" document because it is not practical to write guidelines and design criteria for every possible situation in a community as large as The Islands or to foresee new methods, materials, and technologies that may be developed in the future. Therefore, the Architectural Review Committee, with approval of the Board, may from time to time adopt, amend, and/or repeal the rules and regulations in the Architectural Guidelines. If the guidelines are silent on a particular topic or specific improvement it does not imply that these improvements are accepted or authorized. The property owner should always seek the opinion, direction and/or rule of the ARC before proceeding. The most current version of can be viewed online at islandscommunity.org.

The property owner's cooperation with and understanding of the Covenants, Conditions and Restrictions (CC&Rs) is the foundation for a high-quality planned community. The information that follows was compiled to provide homeowners easy access to pertinent rules and regulations as well as architectural procedures. Please take some time to become familiar with this document because it serves to provide consistency of standards to the Board of Directors, the Architectural Review Committee, our managing agent, and our property owners. The Architectural Guidelines do not supersede the CC&Rs but are meant to be used as an easy reference. Capitalized terms that are not defined in this handbook shall have the meaning set forth in the CC&Rs. If there is any conflict between this handbook and the CC&Rs, the CC&Rs shall prevail.

Some key points to remember are:

1. Always submit proposals for approval prior to beginning any modifications pursuant to Section 4.5 of the CC&Rs. This includes but is not limited to color schemes, design schemes and materials, structural additions or modifications, and landscaping changes. Just because the Architectural Guidelines may be silent on a particular topic or specific improvement does not imply that these improvements are allowed or acceptable. Please do not assume that a project does not need approval. If you have any questions, call the onsite office at 480-545-7740 or check the website at islandscommunity.org.
2. Keep all letters of approval or denial on file for future reference, if needed.

3. The Architectural Review Committee (ARC) usually meets once a month as noted on the community website at islandscommunity.org or contact the onsite office at 480-545-7740 to confirm the date and time. All submittals must be received the week prior to the meeting date in order to be placed on the agenda. All other submittals received after the deadline will be placed on the agenda for the next month's meeting. Your cooperation and understanding will ensure that The Islands continues to be the exceptional community that our residents desire.
4. Failure to comply with these guidelines may result in the Board taking any action authorized by the governing documents and/or by Arizona law, including but not limited to sending violation notices and imposing fines in accordance with the Deed Enforcement Policy, and/or initiating other legal action.
5. The policies, procedures, requirements, and restrictions set forth in these Guidelines are intended to serve as guidelines. These guidelines are not the exclusive basis for decisions of the Architectural Review Committee (ARC), and compliance with these guidelines does not guarantee approval of any application. Owners should not assume that they are authorized to proceed with any improvements, alterations, exterior additions, or changes or any other work that is included in Section 4.5 of the CC&Rs simply because a particular project is not specifically addressed in this document. The fact that a particular type of project or modification may not be addressed in this document does not mean that owners have authorization to proceed absent express written approval from the ARC.
6. Approval of construction or improvements in the past does not guarantee approval of the same construction or improvements in the future.
7. The ARC reviews submittals only for aesthetic considerations. The ARC does not review or guarantee the quality of the design or construction.
8. These Guidelines shall supersede and replace, in their entirety, any prior Guidelines adopted by the Board. These Guidelines may be amended in the future.
9. All proposed work pursuant to Section 4.5 of the CC&Rs must be submitted to the ARC for written approval and no work may begin without the written approval of the ARC. Following these Guidelines does not eliminate the need to submit plans for approval by the ARC. Even if the proposed work meets the requirements set forth herein, is otherwise permitted by these Guidelines, and/or is identical to another modification that has been approved, it must be submitted for written approval unless specifically noted herein.
10. Please note that the Architectural Review Committee processes and procedures set forth herein are separate and distinct from procedures and requirements imposed by local municipalities. Owners are advised that the Town of Gilbert requires certain permits. It is the Owner's responsibility to comply with the city permit requirements and all other local laws. Compliance with one set of processes and procedures does not constitute compliance with another. Likewise, an approval obtained from one governing body does not guarantee or require an approval by the other.
11. The ARC makes no warranty, expressed or implied, that any plan submitted and approved is in accordance with state, county, or local building codes. Each owner is required to check and receive, as appropriate, all regulatory approvals for any and all construction and changes made to any home or lot.
12. To the extent that any local government ordinance, building code or regulation requires a more restrictive standard than the standards set forth in the Design Guidelines and CC&Rs, the government standards shall prevail. To the extent that any local government standard

is less restrictive than the Design Guidelines and CC&Rs, the CC&Rs and Design Guidelines (in that order) shall prevail.

13. Design Review application forms must be submitted by the homeowner. Applications from home renters or homeowner agents/representatives will not be accepted.

We hope this document helps continue to build a community that will allow for custom improvements, while maintaining the overall aesthetic tone of our vibrant, engaged, and welcoming neighborhoods.

Sincerely,
The Islands Community Association Board of Directors

ARCHITECTURAL REVIEW COMMITTEE (ARC) PROCEDURES

Architectural Requests: The committee will consider each project on its individual merits. Some Sub Associations require approval prior to submitting a proposal to The Islands Architectural Committee. Please include the approval letter from your Sub Association along with The Islands architectural request form.

ARC Form: Please complete the application form, which is available at islandscommunity.org or at The Islands Community Center, and submit it to the onsite management office, at least a week prior to the scheduled ARC meeting. Submittals should include the following: site plans clearly showing the big picture (entire lot) including orientation and relation to other neighbors, to the common areas, and to the lakes. In addition, there should be a zoomed-in detail of exactly what exists now (pictures) and what changes are proposed (drawings, if appropriate). All building material specifications and samples should be supplied. Incomplete applications cannot be considered for ARC review. If a city building permit will be required for your project, it is highly recommended that you obtain approval from the ARC before applying for that permit. Having successfully obtained a city building permit is of no consequence to the ARC when considering your proposal and does not guarantee that the plan will be approved by the committee. For additional major-project information please refer to **Section 20 Main Residential Structures** regarding significant construction/remodeling changes to permanent structures.

ARC Meetings: The ARC meets monthly (first Wednesday of each month) to review submittals received for improvements, alterations, repairs, excavation, grading or other work which in any way alter the exterior appearance of property or improvements, including landscaping. All submittals are due the week prior (last Wednesday of the month) to the ARC meeting.

ARC Approvals and Deadlines: When a building design has been approved by the ARC and the necessary building permit has been obtained from the Town of Gilbert, the applicant shall proceed in a timely manner with the commencement and completion of all construction work. Work shall

commence within ninety (90) days from the date of obtaining the building permit from the Town of Gilbert, or within one hundred twenty (120) days of obtaining approval from the ARC, whichever occurs first. If the applicant fails to commence work within this time period, the approval from the ARC approval may be revoked, requiring that it be resubmitted. The applicant shall complete the construction within one hundred twenty (120) days of the date of the building permit from the Town of Gilbert. Homeowner modifications or alterations that do not require a building permit must be completed within one hundred twenty (120) days of commencement of the modification or alteration, as approved by the ARC.

ARC Decisions: The ARC may disapprove or suspend any application if there is not sufficient information submitted to exercise the judgment required by these guidelines. The property owner may be required, for example, to further provide (at the property owner's expense) an engineering assessment or artist rendering that more clearly depicts the finished impact of the project on its neighborhood and surroundings. If the ARC fails to approve or disapprove an application within forty-five (45) days after an application has met all of the requirements of the CC&Rs and of this handbook, together with any fee required to be paid and any additional information, plans, and specifications requested by the ARC, and any other requirements, have been submitted to the ARC, the review time will be deemed to have been extended for thirty (30) days. After the thirty (30) day extension, if the plans and specifications have not been approved, the application will be deemed to have been disapproved.

Right to Appeal: Any property owner aggrieved by the decision of the ARC may appeal the decision by submitting a written request to the Board. Such appeal must be made within fifteen (15) days after the decision of the ARC and must be accompanied by the written decision of the ARC, copies of the application and all items submitted to the ARC, and any other relevant evidence previously submitted to the ARC.

A note on existing conditions: Whereas the Board and the Committee strive for consistent enforcement of the Architectural Guidelines, there are existing conditions that do not comply with the current criteria.

In such cases, the Board and the Committee may exercise their right to allow exceptions if the work in place is validated as in place when the property was purchased (pre-existing) or perhaps built with Islands approval under prior guidelines (grandfathered).

However, where installations on private properties infringe in any way on common area facilities or infringe on property line setbacks, the Board may compel the Islands Management to pursue enforcement actions, regardless of when they were installed and if they were unapproved by the Association.

Community Park Rules and Regulations

PARK HOURS ARE FROM SUNRISE TO 11PM

1. Swimming, pool inflatables, standup paddle boards and unauthorized watercraft in the lakes are prohibited.

2. Pets must be on a leash at all times. Owners are responsible for cleaning up after their animals. No livestock is allowed in the park without prior written approval from the Board.
3. Skateboards, scooters, bikes, and roller blades are restricted to sidewalks only and must yield to walkers and pedestrians.
4. No motorized vehicles of any kind are allowed in the park, except in areas designated for such vehicles.
5. Ramadas are available on a first come, first served basis. Please clean up the area when you are done. Inflatables must be registered with The Islands onsite office.
6. Horseshoes, basketball, and volleyball games are limited to areas designed for such activities. Golfing is not allowed in the park.
7. No alcohol is allowed in the park.
8. No glass containers are allowed in the park.
9. No fireworks, firearms or weapons are allowed in the park.
10. No sale of food, beverages, or other items is allowed in the park without prior written approval from The Islands onsite office.
11. Feeding the ducks, geese and any other wildlife is prohibited.
12. No damage or misuse of the park equipment or grounds is allowed. The Islands onsite office has the right to escort individuals out of the park if needed.
13. In the event of an emergency or suspicious activity, please call 9-1-1 OR the Town of Gilbert non-emergency number at 480-503-6500.

**This Park is restricted to Islands residents and their guests only.
Residents must accompany guest(s) while in the park.
Trespassers will be prosecuted in accordance with A.R.S. 13-1502**

Community Lake Use Rules and Regulations

The Lakes within The Islands Community are private lakes exclusively intended for the personal use of individual property owners (or their long-term property lessees) and shall not to be used in any fashion for a commercial or profit-making activity or enterprise, or for on-site or watercraft-mounted advertising/promotion of any type.

These Rules and Regulations are meant to protect residents and their guests. Please respect them for your benefit as well as that of your neighbors. –Your Board of Directors

Swimming

1. The lakes are not treated for swimming; therefore, swimming in The Islands' lakes is strictly prohibited.

Fishing

1. A valid Islands' fishing license shall always be available upon request from land or on a boat on any of The Islands' lakes.
2. Fishing is by catch-and-release only. Please properly dispose of deceased fish, if necessary.
3. Please use single – pointed barbless hooks only.

4. Fishing lines cannot be unattended and a maximum of two poles per person will be allowed.
5. Fish in The Islands lakes are not meant for human consumption.
6. An Islands Community Permit is required and can be obtained at The Islands onsite office. Fishing lines cannot be unattended.

Boating

When boating on The Islands lakes, do so at your own risk. The Association is not responsible for any damage or injuries, including but not limited to damage to boats, docks, etc.

1. Boating is restricted to owners, residents, and their guests.
2. All watercraft operated on any of The Islands' lakes must be registered with the Association, whether stored on or off the water. Registration stickers must be attached above the waterline on the side, front or back of the watercraft. Watercraft registration is non-transferable and non-refundable.
3. Watercraft size shall not exceed twenty-one (21) feet in length and no more than nine (9) feet in width.
4. It is recommended that watercraft owners and operators maintain public liability insurance covering water and boating hazards.
5. Water vessels must use the community's permanent dock ramps for entry to or exit from the lakes.
6. Each property can have up to three watercrafts visible from lakefront property. Canoes and kayaks are the only permissible watercraft that may be stored out of the water.
7. Watercraft shall be factory-made by a reputable boat manufacturer and shall be Coast Guard approved.
8. No internal combustion engines designed for propelling watercraft shall be permitted to be mounted on or carried aboard watercraft while in any of The Islands' lakes (*except for converted motors*). Watercraft propulsion methods are limited to electric motors, sails, oars, and paddles.
9. Nothing, including watercraft, shall be tethered to the lake wall.
10. Watercraft operated after dusk shall show a white light visible from 360 degrees. Utmost caution is required to preserve safety and serenity. No loud music shall be permitted to be played or originate from any watercraft.
11. The use of watercraft that lack permanently installed navigational lighting (e.g., kayaks, paddle boats, canoes, etc.) is prohibited except during daylight hours.
12. Paddle boards (surf/boogie boards) are prohibited.
13. Swimming pool-type watercraft floats, inner tubes, wind sails and catamarans are prohibited.
14. It is up to each individual Owner to ensure that their watercraft is equipped with flotation sufficient to float craft and crew when awash.
15. It is up to each individual Owner to ensure that safety-approved preservers for each crew member and passenger are available on board all boats at all times, and that any and all other necessary safety precautions are implemented and observed. For health and safety reasons, individuals under eight (8) years of age and non-swimmers should wear life preservers whenever boating.

16. Watercraft shall be tethered so as not to encroach onto neighboring lakefront properties or to impede navigation.
17. Watercraft shall not be operated so near the shore of the lakes as to unnecessarily disturb the owners or residents or otherwise create a nuisance.
18. The only acceptable anchor for the Islands community is a 10LB Mushroom anchors. Any other anchor including the rubber coated river anchors are unsafe for lining of the lake, as well as anchor with blades, teeth, or extendable arms.
19. Anchors should be no more than ten pounds maximum weight.
20. Remote Control watercraft are only allowed if they are registered with a watercraft permit to an Islands resident.

ARCHITECTURAL GUIDELINES - RULES AND REGULATIONS

1. Animals/Pets

1. Sanitation or health concerns may be reported to the Maricopa County officials.
2. Fowl (*per the Town of Gilbert's definition that 'fowl' means chicken, duck, turkey, pigeon, macaw, parrot, peacock, and other large, domesticated bird*) is not a recognized outdoor yard pet.
3. No structure for the care, housing or confinement of any animal shall be visible from neighboring properties, the street, or any common area, including but not limited to the lakes.
4. No animal (including but not limited to birds) shall be permitted to make an unreasonable amount of noise or create a nuisance. The Board shall have the exclusive authority to determine the existence of a nuisance. Please report barking dog nuisance issues to the Town of Gilbert Police Department (non-emergency number: 480-503-6500).
5. Owners are responsible for the behavior of their pets, whether on or outside of the owner's lot.
6. Each household is responsible for cleaning up after his or her animal(s), as well as complying with city and state leash laws. Pet owners are responsible for retrieving, carrying and disposing of any feces deposited by their pet(s). For your convenience, pet waste bag stations are provided throughout the community.
7. No pet feces shall be permitted to enter or be disposed of in the lake at any time.
8. Maricopa County also regulates the type and quantity of household pets. For questions or concerns, please contact Maricopa County directly.
9. Feral "pets", defined as domestic type house animals such as dogs and cats, that are allowed to roam unrestricted onto the property of other members, are strictly prohibited. No owner is allowed to feed feral pets.

2. Antennas, Satellite Dishes, Internet Access & Wires/Conduit

1. Any antenna, satellite dish or internet access device must not be visible from neighboring properties, the street, or any common area (including but not limited to the lakes). Owners may only install any antenna, satellite dish or internet access device in an area that is visible from neighboring properties, the street, or common area if the Owner would not be able to

install the device or it would impair the functioning of the device or restrict its use or adversely affect the cost of the device.

2. Any wires and/or conduit visible from the street or neighboring properties must be strung in a taut line against the home and closely match the home's paint to make the wires appear less visible.

3. Awnings, Retractable Awnings, Roll Shades (semi-permanent structures)

1. Only solid colors will be considered.
2. Owners shall perform regular maintenance/replacement of faded, torn or ripped canvas on awnings/roll shades, which shall be kept free of sand, dust, and spider webs.
3. The Association retains the right to determine when an awning/roll shade must be repaired and/or replaced due to weathering, fading, tearing, ripping, etc.
4. All structural frame damage shall be repaired, replaced, or removed in a timely manner.
5. Roll shades used to screen the patio shall be mounted on the inside of the fascia board and shall be neutral in color.
6. The ARC recommends that awnings/roll shades have a minimum five (5) year guarantee/warranty from the manufacturer to ensure a high-quality awning. When submitting, please identify the manufacturer's name, the awning color, and the type of material, and provide a sample of the material to be used.

4. Basketball Hoops

1. Basketball backboards installed on the house are prohibited.
2. Permanent basketball goals must meet the following requirements:
 - a. The ground-mounted pole and backboard brackets shall be black in color or painted to match the body color of the home.
 - b. The pole shall be placed so as not to interfere with the neighbor's enjoyment of their property. You may consider adding landscape screen to minimize the pole/hoop.
 - c. Basketball goals installed in fully enclosed backyards must meet the ground pole requirements. Pole-mounted lights for sport courts are not permitted.
3. Portable basketball goals shall meet the following requirements:
 - a. The pole shall be placed so as not to interfere with the neighbor's enjoyment of their property. Consider adding landscape screen to minimize the pole/hoop.
 - b. Portable basketball goals may be set and weighted with water or sand, per manufactures recommendations, at the side of the driveways edge.
 - c. Goals may not be weighted by sandbags, concrete blocks or other objects that may be placed on top of the base.
 - d. Hoops are not to be placed, stored, or used in the street, sidewalk or middle of the driveway.
4. The pole, backboard and netting must be maintained in good working order.

5. Clothes Lines

1. No outside clothes lines or other facilities for drying or airing clothes shall be placed on any lot or parcel.

6. Driveways & Extensions

1. Driveway extensions will be reviewed on an individual basis with consideration of any impact on the architectural features of the neighborhood. All approved additions must be landscaped to maintain visual harmony within the existing neighborhood. Plants/ trees that are displaced due to the extension shall be replaced in other areas of the front yard.
2. A driveway extension shall not be permitted if it creates an uninterrupted span of poured concrete and additional pavers greater than twenty-eight (28) feet at the sidewalk or fifty percent (50%) of the lot width.
3. A minimum five (5) feet landscape buffer shall separate adjacent driveways.
4. Painting of driveways is not permitted.
5. Colors and texture samples shall be included with ARC submittals.
6. One alternate material may be used for a driveway extension or match the existing material.
7. Driveway extensions using materials such as pavers where possible and when possible, maybe applied to both sides of the driveway to add symmetry.

7. Dumpsters, Portable Temporary Storage Units, Porta-Pottys

1. Dumpsters (temporary construction dumpsters), Portable temporary storage units (PODS, Smart Boxes, or other similar moving and storage companies), Porta-Pottys (Portable toilets) may be permitted under the following conditions.
2. The Property Owner is responsible for providing prior written notice to the onsite office, supplying the dates and intent of the use of the dumpster/temporary storage unit or porta-potty. Having ARC approval on a project does not automatically permit use of the dumpster/temporary storage unit or porta-potty.
3. The dumpster/temporary storage or porta-potty unit may be allowed for two (2) weeks in any calendar year.
4. The length of time needed for the dumpster/temporary storage unit or porta potty may be extended through communication with the Management Staff/Board of Directors and/or Architectural Review Committee. Additional time may be granted for extenuating circumstances. The management staff reserves the right to grant additional time as determined on a case-by-case basis.
5. The preferred location for dumpsters/temporary portable storage unit is in the driveway. Dumpsters/temporary portable storage units must fit in the driveway and may not block the sidewalk. Placement on the street may be considered if sidewalks, pedestrians, vehicular traffic, or sightlines for vehicular traffic are not impeded.
6. Only one porta potty may be in the front of the property for the purpose of supporting approved construction and should be positioned out of view of neighboring properties as much as possible.
7. The maximum size porta-potty is to be single-standard occupancy.
8. The porta potty must be cleaned at a minimum of one time per week.
9. Dumpsters shall be routinely emptied as needed to avoid overflow of waste and materials.

8. Fire Pits, Kivas, Barbecue Pits (outdoor kitchens)

1. The ARC submittal for any permanent exterior fireplaces, kivas, barbeque pits, or outdoor kitchens should include a plot map drawing, materials, and colors to be used.

2. Placement of the above shall be set back five (5) feet from adjacent party walls and shall not exceed eight (8) feet in height.

9. Flags and Flag Poles

1. In no event shall the flagpole be higher than the rooftop of the home.
2. Only one flagpole is permitted per lot.
3. The only flags that may be flown on the flagpole are those specifically identified by A.R.S. §33-1808:
 1. The American Flag or an official or replica of a flag of the uniformed services of the United States if the American flag or a uniformed services flag is displayed in a manner consistent with the federal flag code (P.L. 94-344; 90 Stat. 810; 4 United States Code sections 4 through 10).
 2. The POW/MIA Flag.
 3. The Arizona State Flag.
 4. An Arizona Indian Nations Flag.
 5. The Gadsden Flags.
 6. A first responder flag. A first responder flag may incorporate the design of one or two other first responder flags to form a combined flag.
 7. A blue star service flag or a gold star service flag
 8. Any historic version of the American flag, including the Betsy Ross Flag, without regard to how the stars and stripes are arranged on the flag.
4. Only two flags may be displayed on the flagpole at once.
5. Please refer to flag etiquette at usflag.org/flagetiquette.html.
6. In addition to the flags that may be permitted on the flagpole, only one decorative or seasonal flag ("Decorative Flag") is permitted per lot, and such Decorative Flag must be mounted on the house below the roofline, not on the free-standing flagpole.
7. The size of a Decorative Flag cannot exceed three (3) feet by five (5) feet in dimension.
8. Decorative Flags may not be graphic in nature or include nudity, profanity, or any subject matter that is detrimental to the community. The Board shall be the sole judge as to whether a Decorative Flag violates this provision.
9. All flags must be well always maintained and in good condition.
10. LED lighted American flags are permitted.

For the purposes of this section, "First responder flag" means a flag that recognizes and honors the services of any of the following:

- (a) Law enforcement and that is limited to the colors blue, black and white, the words "law enforcement", "police", "officers", "first responder", "honor our", "support our" and "department" and the symbol of a generic police shield in a crest or star shape.*
- (b) Fire departments and that is limited to the colors red, gold, black and white, the words "fire", "firefighters", "F", "D", "FD", "first responder", "department", "honor our" and "support our" and the symbol of a generic Maltese cross.*
- (c) Paramedics or emergency medical technicians and that is limited to the colors blue, black and white, the words "first responder", "paramedic", "emergency medical",*

“service”, “technician”, “honor our” and “support our” and the symbol of a generic star of life.

For the purposes of this section, “Betsy Ross Flag” means an historic flag of the United States that consists of thirteen stripes alternating between red and white stripes and thirteen five-pointed white stars arranged in a circle against a blue background.

10. Garbage/Trash

1. Trash containers shall not be visible from neighboring property or the street except on collection day.
2. Trash containers are to be set out no earlier than the afternoon prior to collection and containers are to be removed the evening of trash pickup. Please contact the Town of Gilbert to confirm trash pickup days.
3. No garbage, trash, debris, etc. shall be placed on any lot or parcel except in covered containers meeting the specifications of the Town of Gilbert.
4. Each owner shall be responsible for the removal of rubbish, debris, and garbage from not only his lot or parcel but also from all public right-of-way, either in front of or alongside his lot, excluding (a) public roadway improvements and (b) those areas specified on a Tract Declaration or subdivision plat to be maintained by The Islands Community Association.
5. All household and maintenance items must be stored properly and shall not be left in view of neighboring properties, the street or any Common Area including but not limited to the lakes.
6. Uncontained trash (bulk trash) shall not be set out more than three (3) days in advance of the scheduled pickup. Bulk trash piles may not be larger than ten (10) feet long by five (5) feet wide by five (5) feet high. Place all acceptable bulk items in the street against the curb a minimum of five (5) feet away from all obstacles including trash/recycle containers and vehicles. Please contact the Town of Gilbert to confirm bulk pick-up days.
7. Contact the Town of Gilbert for trash can replacements.

11. Gates

1. All wood material must either be painted to match the wall or house trim, stained redwood or stained in its natural color.
2. Additional gate submittals must include the placement, dimensions, materials, and color of the new proposed gate.
3. Any wrought iron must be painted black or painted to match the color of the wall.
4. Two gates are permitted per lot, and only one of which may be wider than forty-two (42) inches.
5. Gates shall not be constructed within any common wall.

12. Gutters and Downspouts

1. Gutters will be considered for approval if the finish matches the color of the home roofline trim; downspouts are to be directed so as not to drain on neighboring properties and must match the color of the house base color.

2. Plans must include the proposed locations of the gutters and downspouts and the quality of materials. All gutters shall be maintained in good condition.

13. Holiday Decorations

1. Holiday decorations of any nature, including lights, may not be installed more than forty-five (45) days prior to the holiday and must be removed within fourteen (14) days after that holiday in the months of October 1 – January 31. All other months of the year are to have decorations visible only 10 days before holiday and removed 10 days after.
2. Decorative items of any nature that aid in the celebration and/or recognition of seasonal holidays may be hung, set up, displayed, or installed in the owner's front and/or backyard and/ or boat without the need for architectural review and approval, so long as such displays do not become a nuisance as determined by the Board and follow section 13.1.

14. Landscape Artificial Turf

1. To ensure quality of materials, turf should be manufactured in the USA (other materials meeting the below specifications may be submitted for consideration) with a minimum eight (8) year warranty.
2. Installer: turf installer must be Certified by Synthetic Turf Council as well as a licensed contractor in Arizona.
3. Seams: Seams must not be visible. Preferred method would be to cut in "S" pattern.
4. Turf may be installed abutting your side and rear walls if sprinklers are not installed. If sprinklers are installed, then it must be a minimum of three (3) feet from the wall to avoid wall damage.
5. Artificial turf must follow the minimal specifications listed below. Please include a sample of the desired artificial turf with your submittal.
 - a. Face weight with a minimum of 60oz- 70oz (total weight 76oz- 96oz); total weight includes the backing mater.
 - b. Pile Height 1 3/4"-2"

15. Landscape Enhancements/Decor

1. Decorative landscape enhancements may be permitted but must blend with the area's landscape theme.
2. Decorative privacy panels are not permitted in front yards or to be visible from the streets or neighboring properties. (e.g., bamboo, artificial vine fencing, split rail, picket, pipe, wrought iron, etc.)
3. Items shall not be offensive in nature, as determined at the sole discretion of the Board.
4. Only manufactured patio furniture shall be visible from neighboring properties, the street or any Common Area including but not limited to the lakes.

16. Landscape (front yard)

1. A minimum of two (2) trees (at least fifteen (15) gallons in size), are required in the front yard of each home and must be planted in the ground. In addition, a minimum of three (3) shrubs (at least five (5) gallons in size) are required and must be planted in the ground.
2. If a desert landscape theme is used, two (2) column-type cacti (e.g., saguaro, organ pipe, etc.) or two (2) succulent bushes (e.g., ocotillo, etc.) may be substituted for the

- aforementioned trees if they are at least six (6) feet in height. Smaller cacti (e.g., barrel, etc.) may be used in lieu of shrubs.
3. Synthetic plants and flowers are not permitted and, as such, cannot be used to fulfill the minimum requirement guidelines.
 4. All trees and shrubs must be planted a minimum of three (3) feet from any wall.
 5. All landscaping shall reflect the character of the development. Rocks, boulders, patios, sidewalks, landscape timbers, etc., may be used for accent and to create imaginative landscape design.
 6. All decorative edging over three (3) inches in elevation requires ARC approval.
 7. Boulders, mounds, decorative/retaining walls and all additions visible to neighboring properties, the street or any common area including lakes or public property shall not exceed three (3) feet in height measured perpendicular to a line running from finish grade at dwelling to sidewalk.
 8. No tree, shrub or plant of any kind shall overhang or otherwise encroach upon any sidewalk or any pedestrian or bikeway, from ground level to a height of eight (8) feet. No part of any plant containing thorns (e.g., cactus, bougainvillea, etc.) shall be positioned less than three (3) feet clear of any pedestrian/bike area.
 9. All bare earth shall be covered by turf, artificial turf, decomposed granite or other natural rock material to provide a neat, weed-free and dust-free appearance. Artificially colored rock is not permitted.
 10. All landscape lighting should be used for accent only and shall be indirect or low voltage. *(See Lighting Section 20).*
 11. Proper maintenance shall include keeping the areas neatly trimmed, cultivated and free of trash, such as weeds, tree suckers, ground branches, dead foliage, tree stumps and debris. Tree stump removal is required when a tree is eliminated. All paved and concrete areas shall be maintained and in good repair. Lawns will be kept mowed, trimmed and green during the summer. Winter overseeding is not required.
 12. Palm trees are to be trimmed annually by July 15th, and/or as needed, after the flower season or as necessary, to include the front yard, lakefront and any palm tree that is visible from neighboring properties, the street or any common area including but not limited to the lakes.
 13. Rock ground cover:
 - a. If decomposed granite or other landscape rock is used, it must be of an "earth tone" color and not painted white, green, blue, or other bright colors.
 - b. Decomposed granite must be at least one-half (1/2) inch in size and must be spread a minimum of two (2) inches thick.
 - c. All decomposed granite must be maintained to be weed and or grass free.
 - d. No more than two (2) different colors of rock are allowed in the front yard.
 14. River rock shall be one (1) to six (6) inches in diameter and not cover more than fifteen percent (15%) of the front yard landscaping.
 15. Boulders must be indigenous to Arizona and should be grouped and buried proportionally by one-third (1/3) for a more natural appearance.
 16. No bare areas are allowed; all areas must be covered with an approved material (granite, grass, etc.).

17. All areas landscaped with granite or other type of rock must be kept free of pet elimination, debris from plants and trees and other types of refuse.
18. Fine grading and mounding: Fine grading is a critical aspect of landscaping. Each lot is graded so that all storm water will drain away from the home and not onto adjoining properties. It is extremely important that this drainage pattern be maintained when preparing the landscape design, especially if mounding or berms are proposed. It is suggested that mounds not exceed eighteen (18) inches in height. It is also suggested that mounds and drainage swales be kept at least five (5) feet from sidewalks to prevent water collection underneath sidewalks.
19. Irrigation heads/drip system emitters for plants within granite landscaped areas must be kept in good repair and irrigation lines buried, whether or not they support plantings.
20. Sprinkler systems and the water the sprinkler system emits may not encroach on a neighboring home's property and/or common wall and must be kept in good repair
21. Fruit from citrus trees shall be collected before the fruit decays to assist in helping to prevent rodent inhabitation.

17. Leasing of Homes

1. The act of advertising or listing a property as being available for less than thirty (30) days will be considered a violation. Attempting to circumvent this rule with overlapping leases will be considered a separate violation for each lease involved.
2. For each new lease the owner will pay an administration fee of \$25.00, made payable to The Islands Association no later than fifteen days following the effective date of the lease. This fee will not apply to a renewed lease.
3. A property lease shall specify that the leased property and the lessee are subject to The Islands Community Association's governing documents including, without limitation, the Articles, Bylaws, Declaration, ARC Guidelines and Association Rules.
4. Homeowners are required to contact the property management office at 480-545-7740 to report when their home is not owner occupied. This information will remain in the hands of the management company only and is required to maintain optimal communication.
5. It is the owner's responsibility, whether the property is being leased or is owner-occupied, to provide the property management office (825 S. Islands Drive West, Gilbert or call 480-545-7740) with the owner's correct mailing and billing address, email address and telephone or mobile phone number.
6. Depending on where the property is located, the leased property and the lessee may also be subject to sub-association documents, which may include additional restrictions in the form of a Tract Declaration and separate Bylaws.

18. Lighting

A. General

1. No outside lighting, other than indirect lighting and house-mounted decorative fixtures shall be placed, allowed, or maintained on any lot or parcel.
2. House-mounted lighting shall be clear or white, in decorative fixtures, which diffuse light and shall not contain bulbs with wattage greater than sixty (60) watts, including LED equivalent.

3. House-mounted lighting cannot be used as overnight security lighting if it creates a nuisance to neighboring properties.
4. Exterior ground-mounted lighting shall be clear or white, low voltage or indirect. Glare shall not be visible directly from neighboring properties, the street or any common area including lakes.
5. All landscape lighting should be used for accent only, shall be indirect or low voltage, and shall be located/directed to avoid creating a nuisance for adjacent properties.
6. Tennis/sport court, security and other similar lighting will be reviewed and approved on an individual basis. Approval is subject to light type, orientation, site plan, use, brightness, and other factors, which the ARC considers to be in the best interest of the owner, tenants and residents of The Islands. No glare from light sources shall be visible directly toward from neighboring properties, the street or any common area including but not limited to the lakes.
7. Motion-activated lighting may be focused/aimed to as to avoid projection onto any portion of the Common Areas (including but not limited to the lakes) or neighboring lots.
8. No lights may be mounted higher than eight (8) feet measured from the base grade at the footing of the house except for permanent fixtures installed on a second story deck. These second story fixtures, however, are to be shaded or directed to avoid creating a nuisance to neighboring properties, common areas, streets, and lakes.
9. Security lighting shall be allowed if the fixture is not visible from neighboring properties, private or public, and is triggered only by movement on the homeowner's property. Security lighting may have wattage that exceeds sixty (60) watts, including LED equivalent, but shall not remain on for longer than thirty (30) seconds after each triggering movement detected on the homeowner's property. Security lighting must be directed to avoid creating a nuisance to neighboring properties, common are as, streets, and lakes.
10. Tree-mounted accent lighting shall be white or clear, low voltage or indirect. Lighting should not produce glare on neighboring lots and all wiring shall be shielded from public view.
11. All bulb wattages stated above must be LED equivalent in wattage. White light defined as 2700-3000 Kelvin.
12. All light admitted on the home shall be uniform in color and warmth.

B. Decorative/Entertainment/Party Lighting

13. The use of Decorative/Entertainment/Party Lighting is to be restricted to rear yards and used as accent lighting only. It is not permitted to be used as security lighting. Lights installed as noted below may remain up year-round.
14. The colors of lights are to illuminate white light only. No colored bulbs are to be used except for holiday lighting.
15. Lighted patio/pool umbrellas are permitted.
16. Lights may be installed on the lower covered patio of the home, permanent shade structures, pergolas, or gazebos, in accordance with item #5.
17. Strands (wiring) of the lights are to be green, black, or brown. If the lighting will be visible from adjacent properties, the common areas, the lakes, or the streets it shall be installed in a straight taut line with no scalloping or looping to the interior side of the

fascia or framing so that the strand is not visible. Any power supply or extension cords shall not be visible.

18. Mini-lights or decorative low voltage lighting shall be white or clear. This lighting choice is to be used in the rear yard or lake front; lights shall be installed on trees or lower-level patios only.
19. Tree trunks may be wrapped, and power supply and extension cords shall not be seen.
20. Rope lights may be used but must be white.
21. Individual strand (male to female end) wattage may not exceed sixty (60) watts, including LED equivalent.
22. Lights shall not be attached to any other areas of fascia, wood trim, around windows or uncovered patios. If you do not have a covered patio, light that are not permanent fixture may not be installed on your home.
23. Light strands shall not be attached to the lake wall.
24. Lights on shade sails are prohibited.
25. Light strands shall not to be strung in a way that they're visible in the air, example from patio to the tree or from tree to tree, etc.
26. If additional temporary lighting is used for a special event, it must be removed no more than 10 days after the date of the event.
27. All bulb wattages stated above must be LED equivalent in wattage. White light defined as 2700-3000 Kelvin.

C. Permanent architectural/holiday low voltage track lighting – Please also refer to section 13, Holiday Lighting

28. Lighting system must be professionally installed and must be hidden by fascia or architectural coving.
29. Lighting tracks must be color matched to the color scheme of the house, as to blend with the area of installation.
30. Lighting system must be installed in "zones of operation" (in sections or sides of the home). In the event that continued use disturbs neighbors, a section may be dark while other sections remain lit.
31. Pattern displays such as but not limited to racing lights, and strobing flashing lights are not permitted.

19. Mailboxes

1. Bank mailboxes are maintained by the USPS and are located on an easement in favor of the property owners.

20. Main Residential Structures (new construction and rebuilds)

New construction and rebuilds of main residential structures on lots (other than condominium units) shall be governed by A.R.S. § 33-1817. Additional fees may apply. Please contact the onsite management office at 480-545-7740 for further information.

1. Must submit complete plans, renderings and elevations including samples of materials used that also comply with all Association Declarations and governing documents specifically for use of space and landscaping requirements. Plans will be thoroughly reviewed to include appearance, height, and proximity to neighboring properties, and architectural style.

2. Construction builder/designer must attend ARC meeting when project is being presented. An individual meeting may be called to thoroughly review the submitted plans.
3. If the ARC/Board deems it necessary to retain the services of a design professional, architect, landscape designer, engineer, or other authority for consulting purposes in order to thoroughly assess the suitability of the proposal the property owner will be advised. Expenses incurred in securing this type of professional consultation will be borne by the property owner.
4. The overall design and size/scale of the planned structure is to be coherent, consistent, and reflective of the architectural style of the development generally and the neighborhood specifically.
5. Any deviations from approved plans will not be tolerated. Failure to comply with plans may result in legal ramifications.
6. An ARC on-site inspection is to be called for by the property owner prior to the framing of the project and again once framing is complete but has not yet been covered. Additional inspections will be scheduled if requested by the ARC or the Board. Inspections will be conducted by the ARC, the Board, their managing agent, or any construction professionals deemed necessary to ensure the project is being built according to the ARC-approved plans.
7. Review and Approval of the Board may also be requested by the ARC.

21. Outdoor speakers/televisions

1. Any permanently mounted radios, stereos, or televisions cannot be a nuisance to any neighboring properties, as determined at the sole discretion of the Board.
2. Outdoor speakers/televisions cannot be visible from neighboring properties except for lakefront properties with clear views across the water.
3. Installation of outdoor speakers/televisions/radios are limited to the backyards only.

22. Paint

1. Homes and buildings shall be kept in good condition and repair and adequately painted.
2. Exterior painting requires an approval by the ARC each time your home is painted. Therefore, since each approval represents a one-time approval, chosen colors must be submitted for approval even if they are the same colors, prior to repainting.
3. The Islands currently has an approved paint palette with twenty-six (26) color schemes from which to choose. Body colors are to be used solely for the main body of the house. Trim and pop-out colors can be used with the body color. Trim and Pop out colors may not be used on the body of the home. Homes that are side by side may not share the same color scheme. All painting or repainting shall be submitted to the ARC for review, prior to the commencement of painting (even for approved schemes).
4. You are required to use at least two (2) colors when painting your home; however, up to three (3) different colors may be chosen. Colors should be within the preapproved (same) color scheme.
5. When choosing a color scheme, please take into consideration the roof tile and granite colors as well as the landscape design.
6. When submitting a request to paint your home, please note that painting includes the garage doors, outside entry doors and all walls on your property.

- a. Garage door(s) are required to be painted at the time of repainting your home and/or at the time of replacement. The garage door(s) shall be one of the three colors of your requested (body, trim or pop-out) color scheme, unless your garage door has an existing factory finish already approved by the Architectural Review Committee and that finish is still in good condition.
 - b. Outside entry door(s) are required to be painted at the time of repainting your home and/or at the time of replacement. The outside entry door(s) typically need to be one of the three colors of your requested (body, trim or pop-out) color scheme.
 - c. Walls on your property are required to be the same color of the body of your house. Walls refer to all types of walls on your property including shared walls, Party Walls, neighboring, decorative, retaining and garden walls. Walls refer to all exterior walls to include front, rear and lakeside.
7. The ARC reserves the right to request a sample to be painted on the home for onsite inspection, if submitting for a variance of the approved color schemes.
 8. Approved color schemes may be viewed at the following locations:
 - a. Dunn Edwards: dunnedwards.com or Sherwin-Williams: sherwin-williams.com
 - b. The Islands community website: islandscommunity.org
 - c. The Islands Community Center, 825 S. Islands Drive West
 9. Other paint vendors can be used by duplicating The Islands approved Dunn Edwards or Sherwin-Williams paint color code recipe exactly.

23. *Patio Covers (permanently attached to the house)*

1. The application for approval shall include all architectural plans, site plans, elevation drawings, roof material; color and style shall match existing; material and texture must match the existing body of the home.
2. Patio covers and shade covers are an integral part of the house structure, therefore, they shall comply with setback standards of at least five (5) feet from a shared wall.
3. Also, reference "Awnings, Retractable Awnings, Roll Shades" and "Structures".

24. *Play Equipment, Swing Sets, Trampolines*

1. When considering plans, the ARC will consider the appearance, height, and proximity to neighboring properties and may require the homeowner to add additional plants/foliage to conceal the structure.
2. Submittals must include a picture or brochure of the structure, with dimensions, materials, colors and a plot plan, map or drawing indicating the proposed location and its proximity to adjacent property lines.
3. Any set that is greater than greater than ten (10) feet including the canopy and supporting structure, shall not be approved. Platforms shall not be taller than five (5) feet from the ground.
4. All play equipment shall be a minimum of five (5) feet away from any wall.
5. Trampolines: the maximum height that shall be approved for trampolines and safety netting is ten (10) feet. Trampolines must be placed at least five (5) feet from all surrounding walls and screened to be unobtrusive and hidden from view as much as possible.

25. Pools/Spas

1. No drainage piping shall be allowed to discharge into the lake or Islands Common Areas.
2. Backwash, and any other water releases shall not be permitted into the lake or Islands common areas. Check with the Town of Gilbert ordinance requirements for backwashing.
3. Above ground spas shall be painted the same color as the body of the house, or a non-colored wood preservative may be used.
4. Above ground pools with attached decks shall not be placed within ten (10) feet of any party wall. Pool equipment shall be screened from view from the common areas, the streets and the lakes using materials and finishes matching the adjacent or nearest structure on the property.
5. The owner shall provide access to contractors through their lot ingress, if possible. Any construction that requires the removal of common walls may require a deposit and written approval from the Board.
6. Any walls removed during construction of a pool, spa or other approved improvements shall be replaced in its original state without any modifications, immediately after construction is complete, including matching blocks/tiles, construction, paint, and stucco, if applicable.

26. Roofs

1. "Built-up" type roof covering material for patio covers (i.e., rolled roofing) shall not be visible from the neighboring properties, the street or any common area including but not limited to the lakes.
2. Generally acceptable roof materials shall be concrete tile or clay tile and shall be restricted to colors approved by the ARC on an individual basis.
3. Roof pitch is restricted as follows: four-twelfths (4/12) minimum for tile roofs, one-quarter (1/4) foot per foot pitch for patio covers as a minimum.
4. All vent pipe stacks and equipment protruding above the plane of the roof and visible from neighboring property shall be painted and/or screened to match the roof as approved by the ARC.
5. There shall be no turbine roof vents installed on any home or other visible structures in The Islands.

27. Screen Doors and Security Doors

1. Wrought iron security/screen doors need not be submitted for approval provided they are painted to match the base color of the home, are a neutral "earth tone" color or black.
2. Silver-colored aluminum screen/security doors and/or wire screen mesh doors are strictly prohibited on front doors.
3. Roller-type shades shall not be used as exterior door or window coverings.
4. For sunscreens, see "Windows".

28. Screened Patios (porches)

1. Screened patios shall appear architecturally integrated with the existing structure. Colors, material, and texture must match the existing body of the home.
2. The knee walls or base wall which secures the screen material shall be a minimum of thirty (30) inches from finished grade or the sill height of the lowest adjacent window, whichever

is lower, made of similar building components including but not limited to stucco, brick, or stone façade. A framing material sample must be submitted and shall be integrated with the color of the home.

3. A sample of the screen material shall also be submitted and should not be in contrast with existing screens on the home. Screens shall be maintained in like new condition.

29. Security Cameras & Security Lighting

1. Security cameras are permitted on homeowner's property. Security cameras are not to be pointed at neighboring lots and must be as unobtrusive as possible when mounted to the home.
2. Security camera must be mounted to the property owner's home, at a height that does not exceed 8 feet.
3. Security lighting is to not be higher than 10 feet on the front and 8 feet on all sides of the home.
4. Motion-activated lighting may be focused/aimed to as to avoid projection onto any portion of the Common Areas (including but not limited to the lakes) or neighboring lots.
5. Security lighting shall be allowed if the fixture is not visible from neighboring properties, private or public, and is triggered only by movement on the homeowner's property. Security lighting may have wattage that exceeds sixty (60) watts, including LED equivalent, but shall not remain on for longer than thirty (30) seconds after each triggering movement detected on the homeowner's property. Security lighting must be directed to avoid creating a nuisance to neighboring properties, common areas, streets, and lakes.

30. Signage

1. All signs shall conform and comply with appropriate governmental statutes and ordinances.
2. Political, children at play, for sale, for lease, for rent and open house signs must comply with A.R.S. § 33-1808, as amended (for single family homes) and A.R.S. § 33-1261, as amended (for condominium units).
3. A political sign is defined as a sign that attempts to influence the outcome of an election, including supporting or opposing the recall of a public officer or supporting or opposing the circulation of a petition for a ballot measure, question or proposition or the recall of a public officer (pursuant to Arizona Revised Statutes 33-1808). Political signs may be displayed no earlier than seventy-one (71) calendar days prior to the election and removed fifteen (15) calendar days after the general election if the candidate advances to the general election. If the candidate does not advance past the primary, the sign must be removed within fifteen (15) days after the primary election.
4. An Association-Specific Political Sign means a sign that supports or opposes a candidate for the board of directors or the recall of a board member or a planned community ballot measure that requires a vote of the association members (pursuant to Arizona Revised Statutes 33-1808). An association specific political sign may be displayed no earlier than the date the Association provides written or absentee ballots to members and no later than three (3) days after the planned community election. Profanity and discriminatory text are not permitted on any association-specific political sign. The maximin aggregate total dimensions of all association-specific signs on a member's property shall not exceed nine square feet.

5. Signs shall not be allowed on or at the fountain or in the adjacent Common Areas.
6. Real estate, garage sale, "For Sale" or directional signage may be placed for up to 48 hours in other Common Areas.
7. Permanent signs shall not be placed in the common areas, attached to the surface of any wall or any area for which the Association has maintenance responsibility.
8. A maximum of two (2) identification signs (name or address) per residential unit with an area no greater than seventy-two (72) square (12" L x 6"H) inches shall be permitted.
9. Address numbers are required and must be visible from the street.

31. Solar Energy Devices (including solar panels)

Solar energy devices (including solar panels) shall be governed by the Solar Energy Device Guidelines. *See exhibit 7*

32. Storage Sheds (prefabricated or manufactured)

1. When considering plans, the ARC will consider the appearance, height, location, and proximity to neighboring properties and may require the homeowner to add foliage to appear less visible.
2. The color of the manufactured shed shall be of a neutral color and should match the existing color of the home.
3. In an effort to protect a shared or common wall (i.e., a party wall), structures shall not be attached to the party wall.
4. The highest point of the shed should not exceed the shared wall by more than two feet.
5. Maximum of one (1) structure per lot.
6. Structures are to be maintained in good repair and condition at all times.
7. Should not exceed the property wall.

33. Structures, such as Shade Structures, Pergolas, Ramadas, Gazebos, Pavilions, Sail Shades or other similar structures (prefabricated, manufactured or temporary- built for portability and can be easily moved)

1. Structures must have a minimum five (5) foot setback from any wall.
2. Canvas covers must be solid earth tone in color and within The Islands paint palette
3. Maximum of one (1) structure per lot.
4. Must be professionally designed or manufactured, no homemade structures or PVC pipe construction will be permitted.
5. Structure must be free-standing. It may not be attached to home or any wall in any way, including ropes or lines.
6. Maximum height of ten (10) feet.
7. Maximum square footage of one hundred forty-four (144) square feet
8. Structures are to be always maintained in good repair and condition.

34. Structures, such as Storage Sheds, Guest Houses, Ramadas, Gazebos, Pergolas, Pavilions, or other similar structures (permanent- Free Standing and fixed to the ground and unable to move around the property)

1. The application for approval shall include all architectural plans and elevation drawings.

2. The structure shall comply with setback standards to be at least five (5) feet from a shared wall.
3. Roof color and style shall match the existing roof.
4. Gazebo roofs and pergolas (open lattice/wood roof of natural color) may also be considered for approval.
5. Wall color and texture shall match the existing body of the home.
6. Guest homes and solid wall structures must comply with any applicable Town of Gilbert regulation or ordinance.
7. Maximum of one (1) structure per lot. 8. Structures are to be always maintained in good repair and condition.

35. Tennis/Sport Courts

1. Courts may be allowed providing their setting, visual appearance, lighting, noise generation, construction and landscaping do not detract from the enjoyment of a neighboring property as determined by the ARC. Each proposed installation shall be reviewed on a case-by-case basis.

36. Walkways

1. Walkways shall be no wider than three (3) feet and must be placed so as not to detract from the architectural features of the existing home and neighboring homes and shall not be used as parking for vehicles. Plot plans, detailing the existing home and the proposed walkway, shall be submitted to the ARC along with the intended finish texture of the walkway (for example: salt finish, tile, etc.).
2. One (1) alternate material may be used for a walkway or match the existing material.

37. Walls and Fences

1. Side and rear walls may not exceed six and one-half (6½) feet in height from ground level, as measured from the lowest side of the wall. A fence within fifteen (15) feet of the front property line cannot exceed three (3) feet in height.
2. New fences or walls must match the existing wall in texture and color.
3. Artificial or decorative walls may not be used to raise a wall of fence. New additions must match the existing material, color, and texture.
4. If changing a wall between lots (i.e., a Party Wall), the owners of both lots must sign the form to indicate their approval on the submittal as this wall is shared and both owners are responsible for maintenance thereof.
5. Decorative or garden walls may not exceed three (3) feet in height. Decorative or garden walls must be submitted for approval prior to installation and be finished to match the home in color and texture. Other materials not on the home will be considered on a case-by-case basis. When submitting, be sure to include enough detail and/or samples for the ARC to properly review the submittal.

38. Windows

1. External window frames must be bronze, black, white or match (as closely as possible) the body color of the house. All new or replacement windows must be installed to be inset into

the frame or flush with the wall with a border no thicker than three (3) inches so as to maintain the original architecture as designed by the builder.

2. At the time of replacement, windows must be completed in one (1) phase or in one (1) section of the home in few phases. If windows are scheduled to be completed in multiple phases, the homeowner must submit a time frame as well as an ARC submittal for each phase. If windows are to be done in phases, a section is considered to be one visible area and/or facade AND window style must match the other windows.
3. No materials, including, but not limited to aluminum foil, reflective screens or glass, mirrors, cardboard, newspaper, insulation, drywall, or similar type material, shall be installed or placed upon the outside or inside of any windows.
4. Exterior-mounted security shutters shall not be permitted.
5. Sunscreens shall be permitted in the following colors: black, bronze, brown, tan, and dark gray. Landscape fabric is not an approved sunscreen.
6. Roller shades shall not be used as exterior window coverings.
7. Association retains the right to determine when a window screen/sunscreen must be repaired and/or replaced due to weathering, fading, tearing, ripping, mismatched, missing, etc.
8. Window mounted air conditioning units are not permitted.
9. Interior window coverings are to be always maintained in good repair and condition.

39. Wind Energy Devices:

1. Wind energy generating devices (such as wind turbines) are not permitted.

LAKEFRONT ARC GUIDELINES - RULES AND REGULATIONS

40. Lakefront Ownership

1. Lakefront homeowners shall also comply with ALL of The Islands' Guidelines for Homeowners, as stated in this document in addition to the following guidelines.
2. All watercrafts shall have an Islands' boat permit. Please contact the onsite management office at 480-545-7740 for more information, or go to islandscommunity.org
3. Each property can have up to three watercrafts visible from lakefront property. Canoes and kayaks are the only permissible watercraft to be stored out of the water must be stored neatly Kayaks that are stored in the water shall be tethered within 18inches of the shoreline.
4. All watercrafts shall be maintained to be operable, in good repair and in a neat and well-maintained manner (including seats, shade covers, and manufactured boat covers).
5. All boat covers shall be manufactured and designed to cover the boat and be maintained in good condition. The uses of tarps, drop cloths, etc. are prohibited.
6. Storage of items such as, but not limited to, boats, exercise equipment, maintenance equipment, ladders, etc. shall not be visible from neighboring lakefront properties.
7. Outdoor furnishings, fixtures, and accessories visible from the lakefront properties are to be always maintained in good repair and condition.
8. The Islands lakes are private and meant for the enjoyment of The Islands residents and guests only. Violators will be subject to all trespassing laws. If you are aware of trespassers using the lakes, please contact the Gilbert Police.

9. Please refer to the Community Lake Use Rules prior to boating.

41. Lakefront Docks

1. The ARC has approved two (2) standard boat dock designs which shall be used by owners who wish to construct a dock on a lakefront lot. Prior to commencement of construction, the owner must submit a site plan to the ARC, detailing the exact location of the proposed dock (to scale) showing all intended construction and elevation drawings, including footing and rebar plan. Construction material must be specified along with color detail. No construction except for ARC-approved boat docks shall be permitted within five (5) feet of the inside edge of the lake wall. See exhibits 1, 2, 3 and 4.
2. All docks shall be a minimum of ten (10) feet from any party wall or lot line.
3. Watercraft shall be parked so as not to impede onto neighboring property.
4. A lot with less than seventy (70) feet of lakefront shall be allowed to construct a dock no wider than eight (8) feet. The dock shall not exceed three (3) feet to cantilever past the outer edge of the lake wall.
5. A lot with seventy-one (71) or more feet of lakefront may construct more than one (1) dock with ARC approval and no dock can be longer than twenty (20) feet along the shoreline. The dock shall not exceed three (3) feet to cantilever past the outer edge of the lake wall.
6. The guidelines designate approved dock designs. See exhibits 1, 2, 3 and 4. Any variance to these designs must be approved in writing by the ARC. The location of a dock must also be approved prior to its construction. It is the responsibility of an owner to maintain their dock and waterfront area in a neat, clean, and safe condition.
7. Each owner of a lakefront lot or parcel shall at his/her sole cost and expense keep and maintain all waterfront facilities (dock) and other improvements in good, safe and clean appearance, condition and repair. The obligation of the owner includes periodic repair, painting and refurbishing.
8. The lake walls are defined as being one (1) foot thick, measured from the lake edge of the concrete wall. All measurements which use the lake as a reference point shall use the inside edge. The inside edge of the wall is defined as the furthest side from the water (side closest to the house). All measurements shall be at a right angle and a horizontal plane to the inside edge of the lake wall. Any wall installation must be twelve (12) inches away from inside the lake wall.

42. Lakefront Easement

1. Only typical landscaping materials are permitted to abut the lake walls. With the exception of ARC-approved docks, no structure can be installed closer than twelve (12) inches away from inside the lake wall.
2. The Islands Community Association retains a ten (10) foot lake easement from the inside lake wall. Inside edge of the wall is defined as the furthest side from the water (side closest to the house). This easement is measured from the inside edge of the lake wall, following the curvature of the wall from property line to property line. Owners will be responsible to remove/replace any structure or landscaping installed within the ten (10) foot easement if such removal/replacement is necessary for The Islands to perform any lake maintenance or repair. No portion of a building or a permanent shade structure will be permitted within ten (10) feet of the inside of a lake wall.

3. No drainage piping shall be allowed to discharge into the lake or Islands Common Areas. Backwash and any other water releases shall not be permitted into the lake or Islands common areas.

43. Lakefront Enhancements/Decor

1. Decorative landscape enhancements may be permitted but must blend with the landscape theme and fall within the following guidelines.
2. Enhancements shall not exceed forty-eight (48) inches in height, except fountains which may not exceed seventy-two (72) inches in height.
3. Enhancements may include, but are not limited to, the following items: fountains, nautical items, sculptures, and items such as clay pots and artifacts.

44. Lakefront Landscaping

1. No less than fifty percent (50%) of the area visible from the lake at the shoreline shall be "green" in nature. Decomposed granite or other natural rock may be visible in no more than forty percent (40%) of the remaining area.
2. Decomposed granite or other natural rock shall not be used on any slope greater than 6:1 (16.7% grade, or one (1) foot elevation for each six (6) feet of distance). Artificially colored rock is not permitted.
3. No tree shall be planted within ten (10) feet of the inner edge of the lake wall.
4. Ground cover on the lake's edge shall be maintained and shall not overhang into the lake. Clippings, plant trimmings and cut grass shall not be discharged into the lake.
5. All completed dwellings, sold or unsold, shall have their back yards landscaped no later than ninety (90) days from completion of construction.
6. Prior to completed landscaping projects, all lakefront backyards shall be maintained in a neat, trash-free, weed-free, dust-free condition.
7. Each lot on the lakefront has a wrought iron property dividing fence; the maintenance of this fence is a shared responsibility between neighbors. The fence may be painted Navajo white, black or to match the interior wall color, as long as the color is agreed upon by the neighbors and each side of the lot matches.
8. Fruit from citrus trees shall be collected before the fruit decays to assist in helping to prevent rodent inhabitation.
9. All Lake front landscaping must also comply with sections 14, 15, and 16 of the Association's Architectural Guidelines.

45. Lakefront Lighting

1. All landscape lighting on lakefront backyards shall adhere to the guidelines outlined in Section 18.
2. All landscape lighting on lakefront backyards shall be indirect or low voltage.
3. White or clear patio lights are permitted year-round on lakefront backyards, but such lights shall not be permitted on upper patios or the roof line.
4. Watercraft must follow holiday decoration guidelines.

46. Lakefront Fencing

1. **Duck, Geese or Coot pre-approved fencing deterrents may be installed to meet the following guidelines:**
 - a. May use green or brown stakes no higher than three (3) feet above the ground, no closer than two (2) feet apart and may not be installed onto the lake wall.
 - b. One (1) or two (2) rows of clear or green wire shall be used to be attached tightly to the stakes. The deterrent shall be kept in good repair.
 - c. All other deterrents are prohibited.
2. **Pet and Pool Safety Fencing:**
 - a. Installation of safety fencing may not be installed within the five (5) feet of the lake wall.
 - b. Wrought iron fencing may be used and shall be black, white, or painted to match the house.
 - c. Screened removable fencing may be used.
 - d. Low gauge chicken wire may be installed on property line fencing for the protection of animals.
 - e. No other deterrents shall be installed.
 - f. No gold or silver prefabricated, or manufactured fencing shall be used, even on a temporary basis.
 - g. No low-level scalloped fencing may be used.
 - h. Fencing must be maintained in good repair and condition.

47. Lakefront Shade Structures

1. Minimum ten (10) feet setback is required from the inside of the lake wall.
2. Structures must comply with all rules for shade structures as previously referenced.
3. Pool and or table umbrellas must be always maintained in good repair and condition.
4. Patio curtains must be neutral in color, made of a fabric suitable for outdoor use and must be always maintained in good repair and condition.

48. Lakefront Walls

1. The lake walls are defined as being one (1) foot thick, measured from the lake edge of the concrete wall. All measurements which use the lake as a reference point shall use the inside edge. The inside edge of the wall is defined as the furthest side from the water (side closest to the house). All measurements shall be at a right angle and a horizontal plane to the inside edge of the lake wall. Any wall installation must be twelve (12) inches away from inside the lake wall.
2. The lake walls are designed and intended to last fifty (50) to seventy-five (75) years. Though it is the Association's responsibility to repair and maintain the lake walls, it is the responsibility of each lakefront owner to protect the integrity of the lake wall contiguous to his/her property.
3. Owners may be required by The Islands Community Association to remove any construction within the ten (10) foot easement, if necessary, for the purpose of maintenance or repair. The cost of removal shall be borne by the owner.
4. Nothing shall be built upon, attached to, or supported by the lake wall including the view fence.

5. Lakefront pools, walls, fences requirements:
 - a. No pool, spa, ramada, nor any other structure shall be built within five (5) feet of the inner edge of the lake wall.
 - b. Pool and spa maintenance and operating equipment shall not be visible from neighboring properties, the street or any common area including but not limited to the lakes.

COMMERCIAL ARC GUIDELINES - RULES AND REGULATIONS

Commercial properties are an integral part of The Islands community and will be held to the same high standards of its homeowners. The Board of Directors and/or the ARC reserve the right to request maintenance, painting, repairs, signage, parking lot, wall and landscaping, etc. They also reserve the right to deny a request.

1. All improvements and/or building should reflect the architectural theme of The Islands.
2. Plans and specifications submitted to the ARC shall include detail of the exterior color scheme, including ALL exterior surfaces. The ARC has sixteen (16) approved color schemes to consider. The ARC will consider requests as long as the colors complement The Islands as a whole.
3. Maintenance of commercial properties shall include landscape maintenance by keeping the areas neatly trimmed, cultivated and free of trash, weeds, tree suckers, ground branches, dead foliage, tree stumps and debris. Maintenance includes repair of all paved areas and concrete areas. Buildings shall be kept in good condition, repair and adequately painted.
4. No trash shall be allowed to accumulate outside the dumpsters and shall be disposed of per the Town of Gilbert regulations.
5. No items shall be stored to be seen from the street or neighboring properties.
6. Permanent project identification (monument) signs shall be approved by the ARC and shall conform to The Islands Master Signage Plan and be kept in good repair.
7. The location and design of commercial signs shall be carefully integrated into the building forms and shall be approved by the ARC. Owners/developers of multi-tenant buildings shall submit a sign package for ARC approval prior to the commencement of construction.
8. Advertising banners --e.g., specials, etc. -- are prohibited.
9. Commercial businesses shall not interfere with homeowners' right of enjoyment.
10. Commercial structures shall not exceed the height of a two-story home (36 feet).

TOWN OF GILBERT CODE AND RULES

1. All buildings and structures erected within The Islands, and the use and appearance of all land within The Islands, shall comply with all applicable Town of Gilbert zoning and building code requirements as well as the Declaration, these guidelines, and applicable Tract Declaration.
2. All buildings, developments and structures erected within The Islands shall conform to the development standards adopted by the Town of Gilbert as part of the master planned community known as The Islands.
3. It is the Association's understanding that the Town of Gilbert requires at least twelve (12) business days to perform the first review of your project. Sometimes there is a need for further reviews. It is also the Associations understanding that there is a nominal fee for project submissions. Please allow plenty of time to obtain town approval and permits.

Exhibit 1
Dock Concept A

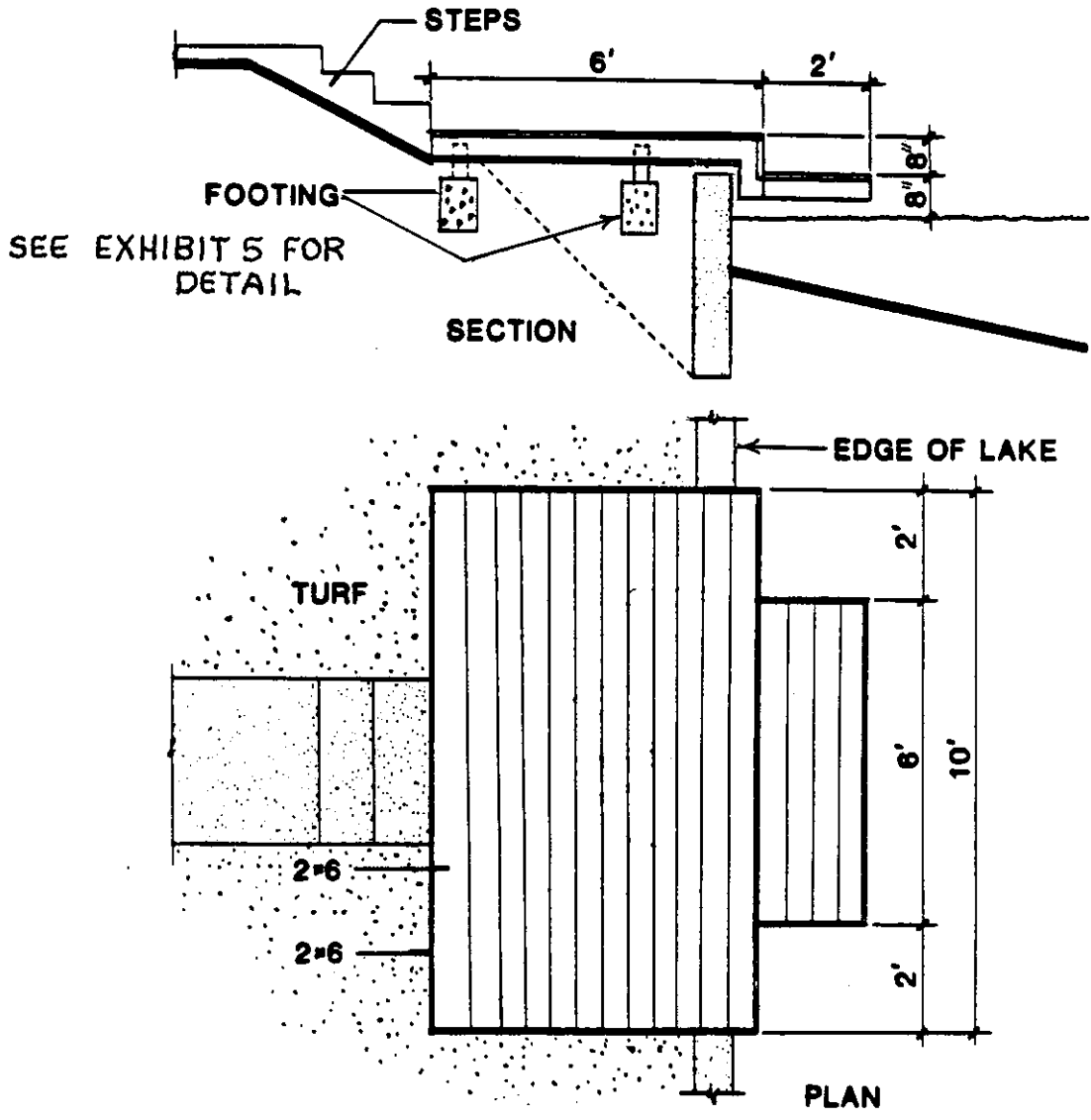

Exhibit 2
Dock Concept B

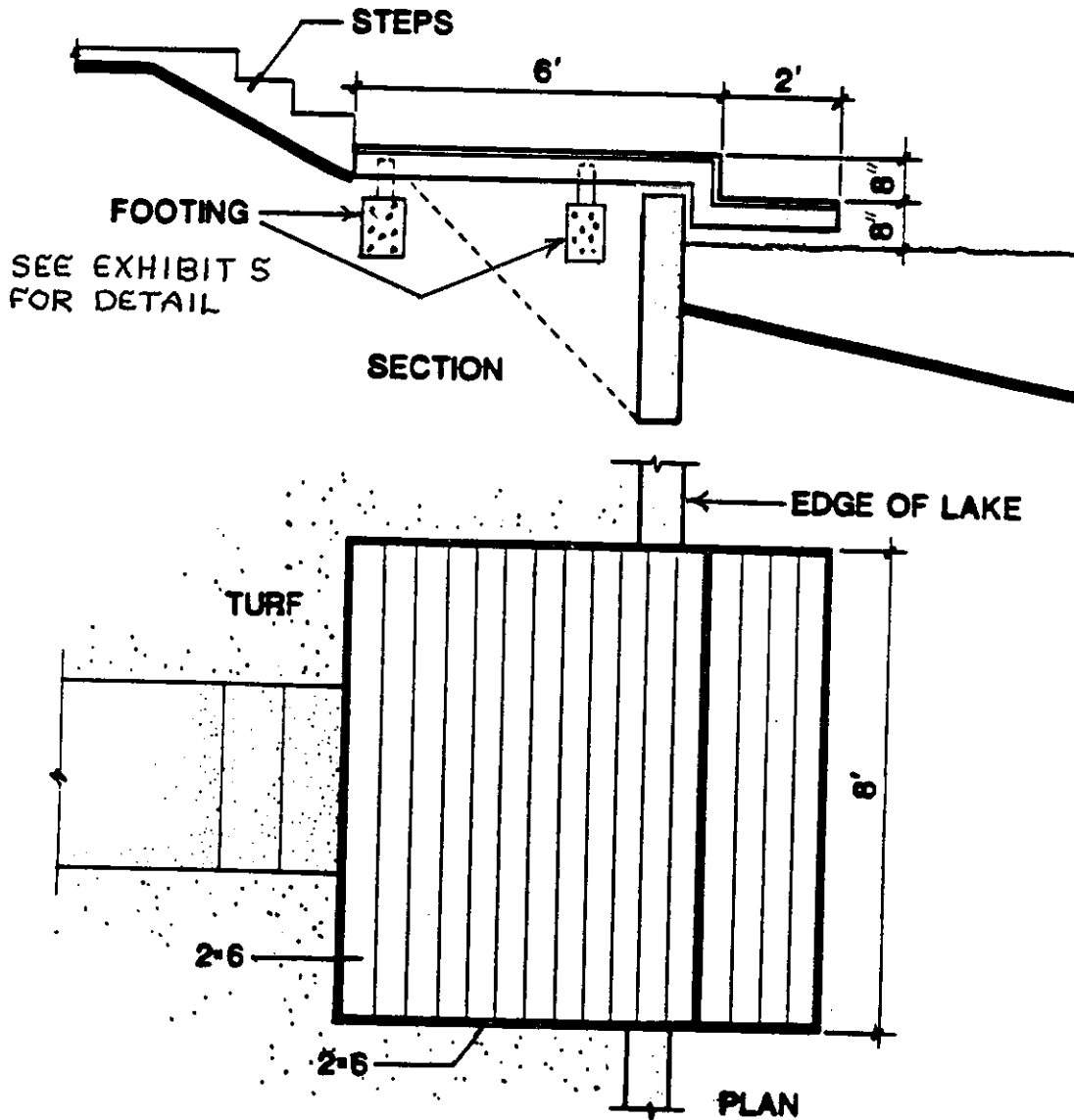
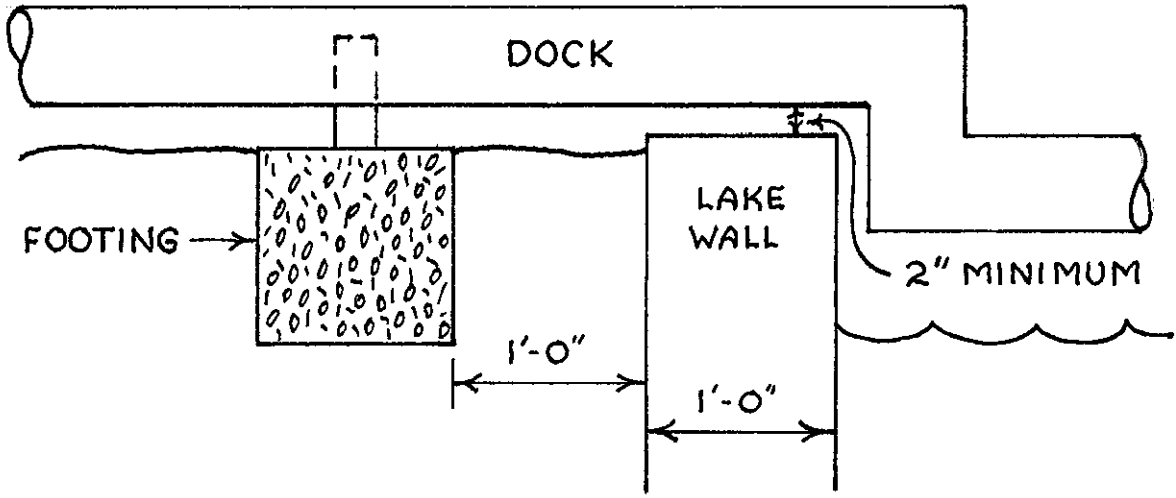

Exhibit 3
Dock Installation/Easement

FOOTING DETAIL



EASEMENT AND LAKE WALL

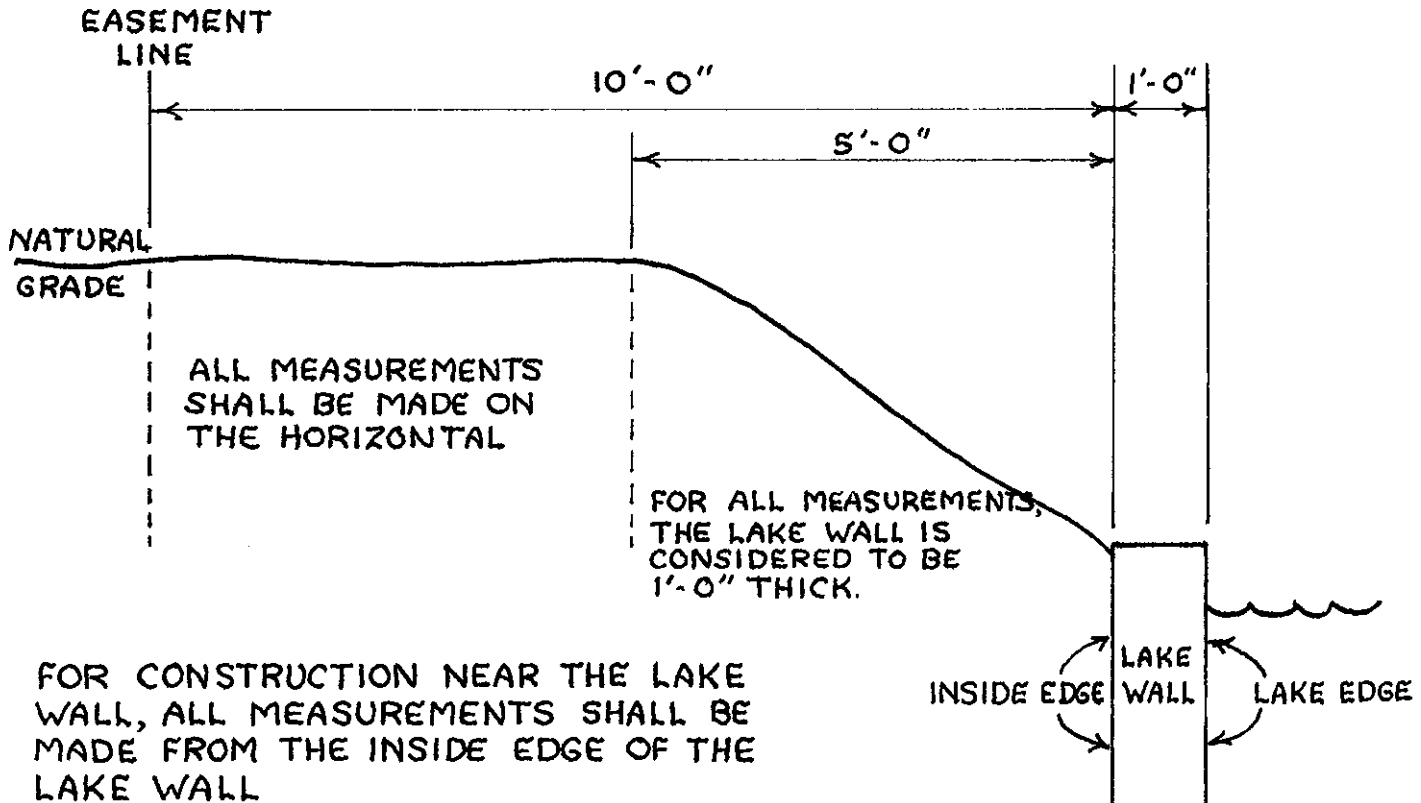
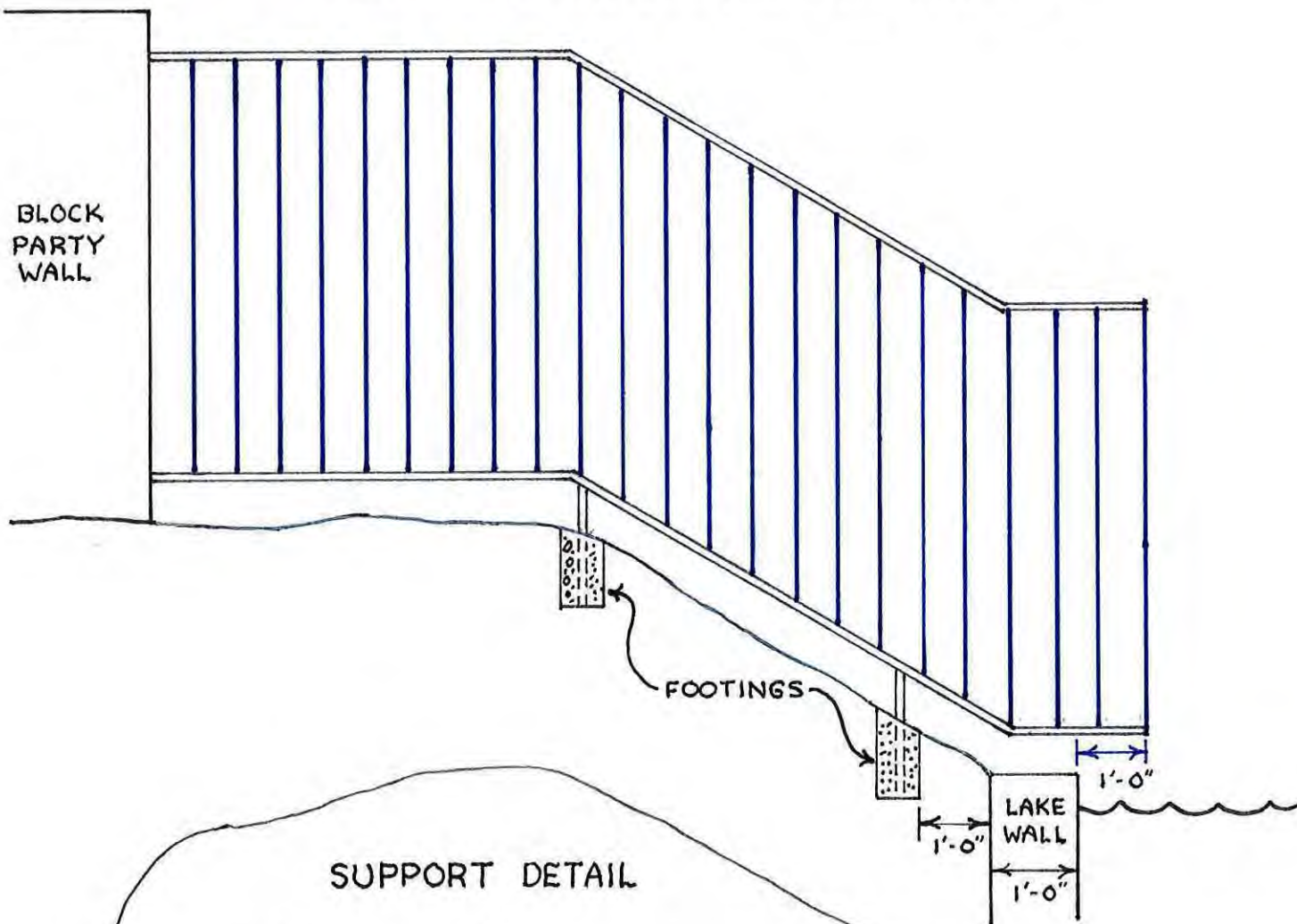

Exhibit 4

VIEW FENCE AND SUPPORT NEAR LAKE WALL



SUPPORT DETAIL

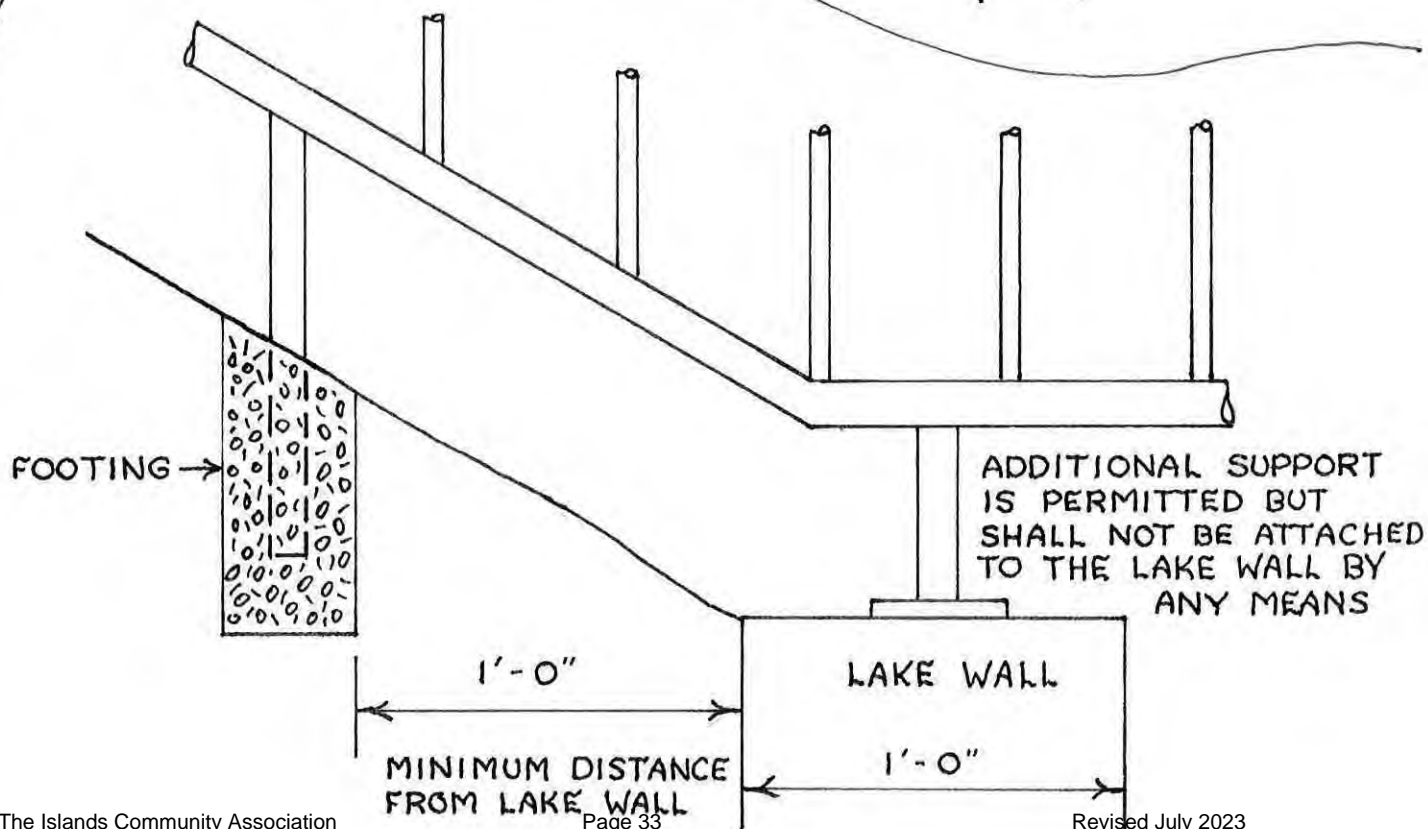

Exhibit 5



For Islands Use Only
Date received in office:
Initials:

COMMUNITY ASSOCIATION

Architectural Submittal Form

Account #: _____

The Architectural Review Committee (ARC) meets on the first Wednesday of each month; Submittals are due by the last Wednesday of each month. **Please include as much detail as possible**, this will help the Committee with your vision. Please return completed forms to the onsite office; you may drop them off, mail, or email. Onsite office hours are Monday-Friday from 8am-5pm. 825 S. Islands Dr. W., Gilbert, AZ 85233
Phone: 480-545-7740 Email: islands.compliance@fsresidential.com

Date: _____ **Owner's Name:** _____

Islands Address: _____

Phone Number: _____ **Email:** _____

Sub Association (if you pay two assessments): _____

Charter Point, Coral Reef, Costain, Laguna Shores, Paradise Cove, Sandcastle, Seawynds and The Falls must have Sub Association approval prior to submitting to The Islands. Please include your approval letter from your sub association.

Lake (if you live on one): _____

Plans are being submitted for (example: landscape, dock, patio cover; basketball hoop, addition etc.):

1. Description, in detail of work to be done (Use additional sheets for drawing of proposed improvements)

2. Type of Materials to be used (Attach samples/brochures/color photos)



<p><i>For Islands Use Only</i></p> <p>Date received in office:</p> <p>Initials:</p>

COMMUNITY ASSOCIATION

3. Contractors Name and Address (if applicable)

Telephone _____ **License #** _____

Submittals should include the following: site plans clearly showing the big picture (entire lot) including orientation and relativity to other neighbors, lakes etc. In addition, there should be a zoomed-in detail of exactly what exists now (pictures) and what changes are proposed (drawings, if appropriate). All building material specifications and samples should be supplied. **INCOMPLETE SUBMITTALS WILL BE DENIED.** Architectural Review Committee requests will be approved, approved with stipulations, denied, or returned for additional information as soon as possible after the review.

The homeowner agrees to maintain improvement, if approved by the Architectural Review Committee. If, in the view of the Architectural Review Committee, the improvement is not being maintained, the Association has the right to maintain the improvement with the homeowner bearing all cost thereof.

The homeowner agrees to comply with all Town and State Laws, and to obtain the necessary permits. Approval by the Architectural Committee shall not be deemed a warranty or representation as to the quality of such construction, installation, addition, alteration, repair, change or other work, or that work conforms to any applicable building codes or other federal, state, or local law, statute, ordinance or rule regulation.

The applicant shall complete the construction within one hundred twenty (120) days of the date of the building permit from the Town of Gilbert. Homeowner modifications or alterations that do not require a building permit must be completed within one hundred twenty (120) days of commencement of the modification or alteration, as approved by the ARC. If the construction has commenced but is not completed, the Association shall have the right to assess the owner for the cost of completion and to collect such costs as provided for in the CC&Rs.

For additional information, please refer to The Islands CC&Rs and The Islands Architectural Guidelines, which may be found at islandscommunity.org or the onsite office at 825 S. Islands Dr West, Gilbert, AZ 85233.

Signature of Owner _____ **Date** _____

For Architectural Review Committee Purposes Only

- Administratively Approved by _____ On this day: _____
- ARC Approved on this day: _____
- ARC Disapproved on this day: _____
- ARC Approved with Stipulation on this day: _____ with the following stipulation:

Exhibit 6



COMMUNITY ASSOCIATION

For Islands Use Only

Date received in office:

Initials:

Paint Request Form

Account #: _____

Colors must be submitted for approval prior to painting. All exterior paint projects include the body of house, trim, pop-out, all property walls and garage doors. Please see The Islands Architectural Guidelines for more information.

Approval process: If pre-approved schemes are chosen, your request can be administratively approved in the office. If colors are combined from multiple schemes or you choose your own neutral colors, the request will need to go before the Committee.

The Architectural Review Committee (ARC): Meets on the first Wednesday of each month; Submittals are due by the last Wednesday of each month. Please return completed forms to the onsite office; you may drop them off, mail, or email. Onsite office hours are Monday-Friday from 8am-5pm. 825 S. Islands Dr. W., Gilbert, AZ 85233
Phone: 480-545-7740 Email: islands.compliance@fsresidential.com

Date: _____ **Owner's Name:** _____

Islands Address: _____

Phone Number: _____ **Email:** _____

Sub Association (if you pay two assessments): _____

*Costain, Charter Point, Paradise Cove, The Falls, and Sandcastle **must have** Sub Association approval prior to submitting to The Islands. Please include your approval letter from your sub association.*

Lake (if you live on one): _____

The Islands approved color palette has 26 schemes containing body colors with corresponding trim and pop-out colors. Body colors are to be used solely for the main body of the house. The ARC has the authority and reserves the right to disapprove a color combination. Homes that are side by side may not share the same color scheme.

Color Scheme #: _____

Body & Property/Retaining Wall Color: _____

Trim Color: _____

Pop-Out Color: _____

Garage Door Color: _____

Front Door Color (if applicable): _____



BY INITIALING IN THIS BOX, YOU AGREE THAT YOUR REQUESTED PAINT SCHEME IS DIFFERENT THAN YOUR SIDE-BY-SIDE NEIGHBORS, PER SECTION 23.3 OF THE ARC GUIDELINES.

Signature of Owner

Date

For Architectural Review Committee Purposes Only

Date _____

ARC Approved; subject to the following conditions: _____

Approved by Administration _____

ARC Approved _____

ARC Disapproved _____





The Islands – Dunn Edwards

Approved Color Palette

https://www.dunnedwards.com/colors/archive/color-ark_pro/the-islands/the-islands

Scheme #1 1. DEW318 Cottage White-Body 2. DEC771 Shaggy Barked-Trim/Pop-Outs 3. DEC752 Birchwood – Trim/Pop-Outs <i>(formerly Steveareno Beige)</i> 4. DET693 Myan Chocolate -Trim/Pop-Outs	Scheme #10 1. DEC715 Sandal -Body 2. DE6169 Milk Mustache -Trim/Pop-Outs 3. DE6124 Whole Wheat -Trim/Pop-Outs 4. DE6062 Tea Bag -Trim/Pop-Outs	Scheme #19 1. DET620 Barnwood Gray - Body 2. DE6384 Iron Fixture- Trim/Pop-outs 3. DEW351 Antique White -Trim/Pop-outs 4. DE6126 Stockhorse - Trim/Pop-outs
Scheme #2 1. DEC751 Ash Gray -Body 2. DEC750 Bison Beige -Trim/Pop-Outs 3. DET624 Sorrel Felt -Trim/Pop-Outs 4. DEW340 Whisper -Trim/Pop-Outs	Scheme #11 1. DEC718 Mesa Tan -Body 2. DEW328 Pearl White -Trim/Pop-Outs 3. DE6135 Verona Beach -Trim/Pop-Outs 4. DEA161 Wild Mustang -Trim/Pop-Outs	Scheme #20 1. DET512 Whale Watching - Body 2. DE6190 Ball of String - Trim/Pop-outs 3. DE6232 Abstract White - Trim/Pop-outs 4. DE6294 Midnight Spruce - Trim/Pop-outs
Scheme #3 1. DE6144 Graham Cracker -Body 2. DEW343 Pearl Necklace -Trim/Pop-Outs 3. DE6142 Floating Feather -Trim/Pop-Outs 4. DET681 Moderne Class -Trim/Pop-Outs	Scheme #12 1. DE6225 Fossil -Body 2. DE6228 Play on Gray -Trim/Pop-Outs 3. DET620 Barnwood Gray -Trim/Pop-Outs 4. DET614 So Chic! -Trim/Pop-Outs	Scheme #21 1. DEC752 Birchwood - Body 2. DEW311 French White - Trim/Pop-outs 3. DE6204 Trite White - Trim/Pop-outs 4. DE6062 Tea Bag - Trim/Pop-outs
Scheme #4 1. DET635 Ecru Wealth -Body 2. DET512 Whale Watching -Trim/Pop-Outs 3. DET626 Metal Fringe -Trim/Pop-Outs 4. DET678 Daydreaming -Trim/Pop-Outs	Scheme #13 1. DET627 Pewter Patter-Body 2. DET680 Espresso Macchiato-Trim/Pop-Outs 3. DET649 Carrara- Trim/Pop-Outs 4. DET620 Barnwood Gray- Trim/Pop-Outs	Scheme #22 1. DET622 Portobello Mushroom - Body 2. DE6071 Spooled White - Trim/Pop-outs 3. DEW339 Bone China - Trim/Pop-outs 4. DE6234 Serene Thought - Trim/Pop-outs
Scheme #5 1. DEC743 High Noon -Body 2. DE6198 Cream Wave -Trim/Pop-Outs 3. DE6173 Paper Sack -Trim/Pop-Outs 4. DEC755 Cocoa -Trim/Pop-Outs	Scheme #14 1. DEC741 Bone White- Body 2. DET510 Gunsmoke- Trim/Pop-Outs 3. DEC743 High Noon- Trim/Pop-Outs 4. DE6111 S'mores- Trim/Pop-Outs	Scheme #23 1. DE6216 Barrel Stove - Body 2. DE6021 Outer Boundary - Trim/Pop-outs 3. DE6214 Pigeon Gray - Trim/Pop-outs 4. DEW351 Antique White - Trim/Pop-outs
Scheme #6 1. DE6206 Desert Suede -Body 2. DE6204 Trite White -Trim/Pop-Outs 3. DE6216 Barrel Stove -Trim/Pop-Outs 4. DEA159 Rich Mocha -Trim/Pop-Outs	Scheme #15 1. DEC754 Quicksand-Body 2. DEW317 Day Lily- Trim/Pop-Outs 3. DE6229 Calico Rock- Trim/Pop-Outs 4. DET634 Downing to Earth- Trim/Pop-Outs	Scheme #24 1. DE6124 Whole Wheat - Body 2. DEC754 Quicksand - Trim/Pop-outs 3. DE6192 Nomadic Taupe – Trim/Pop-outs 4. DE6104 Chic Brick - Trim/Pop-outs
Scheme #7 1. DEC760 Desert Gray -Body 2. DET626 Metal Fringe -Trim/Pop-Outs 3. DEC764 Inside Passage -Trim/Pop-Outs 4. DET653 Historic White -Trim/Pop-Outs	Scheme #16 1. DEC717 Baked Potato- Body 2. DE6128 Sand Dune- Trim/Pop-Outs 3. DE6141 Salt Box- Trim/Pop-Outs 4. DEA163 Rodeo- Trim/Pop-Outs	Scheme #25 1. DEW339 Bone China - Body 2. DE6242 Wells Gray -Trim/Pop-outs 3. DET620 Barnwood Gray -Trim/Pop-outs 4. DE6293 Velvet Clover - Trim/Pop-outs
Scheme #8 1. DET661 Equestrian -Body 2. DET659 Schindler Brown -Trim/Pop-Outs 3. DET660 Natural Radiance -Trim/Pop-Outs 4. DE6223 Mission Trail -Trim/Pop-Outs	Scheme #17 1. DE5490 Antique China - Body 2. DE6392 Mink - Trim/Pop-outs 3. DE6062 Tea Bag- Trim/Pop-outs 4. DE6231 Shaker Gray - Trim/Pop-outs	Scheme #26 1. DE6128 Sand Dune - Body 2. DEW342 Baby's Breath- Trim/Pop-outs 3. DEC766 Steveareno Beige- Trim/Pop-outs 4. DEC702 Antique Rose - Trim/Pop-outs
Scheme #9 1. DET625 Reclaimed Wood -Body 2. DET648 White Picket Fence -Trim/Pop-Outs 3. DET621 Palomino Pony -Trim/Pop-Outs 4. DET622 Portobello Mushroom - Trim/Pop-Outs	Scheme #18 1. DEW345 White Fever - Body 2. DET680 Espresso Macchiato- Trim/Pop-outs 3. DET624 Sorrel Felt - Trim/Pop-outs 4. DE6213 Fine Grain- Trim/Pop-outs	



The Islands – Sherwin Williams

Approved Color Palette

<https://www.sherwin-williams.com/homeowners/color/find-and-explore-colors/hoa/gilbert/az/the-islands/>

Scheme #1 1. SW7554 Steamed Milk - Body 2. SW7052 Gray Area - Trim/Pop-Outs 3. SW9086 Cool Beige - Trim/Pop-Outs 4. SW2856 Fairfax Brown -Trim/Pop-Outs	Scheme #10 1. SW6093 Familiar Beige - Body 2. SW7103 Whitetail - Trim/Pop-Outs 3. SW2823 Rookwood Clay - Trim/Pop-Outs 4. SW6040- Nutshell – Trim/Pop-outs <i>(formerly Less Brown)</i>	Scheme #19 1. SW9169 Chatura Gray - Body 2. SW7674 Peppercorn- Trim/Pop-outs 3. SW 7568 Neutral Ground -Trim/Pop-outs 4. SW6089 Grounded - Trim/Pop-outs
Scheme #2 1. SW6072 Versatile Gray - Body 2. SW7504 Keystone Gray - Trim/Pop-Outs 3. SW7503 Sticks & Stones -Trim/Pop-Outs 4. SW7102 White Flour - Trim/Pop-Outs	Scheme #11 1. SW9093 Nearly Brown - Body 2. SW7105 Paperwhite - Trim/Pop-Outs 3. SW2859 Beige - Trim/Pop-Outs 4. SW6104 Kaffee - Trim/Pop-Outs	Scheme #20 1. SW7746 Rushing River - Body 2. SW7042 Shoji White- Trim/Pop-outs 3. SW 7049 - Nuance - Trim/Pop-outs 4. SW9184 Foxhall Green - Trim/Pop-outs
Scheme #3 1. SW9103 Farro - Body 2. SW7103 Whitetail - Trim/Pop-Outs 3. SW7553 Fragile Beauty - Trim/Pop-Outs 4. SW2807 Rookwood Medium Brown - Trim/Pop-Outs	Scheme #12 1. SW7006 Extra White - Body 2. SW7643 Pussywillow - Trim/Pop-Outs 3. SW9169 Chatura Gray - Trim/Pop-Outs 4. SW7654 Lattice - Trim/Pop-Outs	Scheme #21 1. SW9086 Cool Beige - Body 2. SW6084 Modest White - Trim/Pop-outs 3. SW7551 Greek Villa - Trim/Pop-outs 4. SW7505 Manor House - Trim/Pop-outs
Scheme #4 1. SW6155 Rice Grain - Body 2. SW7746 Rushing River - Trim/Pop-Outs 3. SW7046 Anonymous - Trim/Pop-Outs 4. SW6385 Dover White - Trim/Pop-Outs	Scheme #13 1. SW7044 Amazing Gray - Body 2. SW7675 Sealskin - Trim/Pop-Outs 3. SW7005 Pure White - Trim/Pop-Outs 4. SW9169 Chatura Gray - Trim/Pop-Outs	Scheme #22 1. SW9160 Armadillo - Body 2. SW6028 Cultured Pearl - Trim/Pop-outs 3. SW7012 Creamy - Trim/Pop-outs 4. SW6163 Grassland - Trim/Pop-outs
Scheme #5 1. SW7536 Bittersweet Stem - Body 2. SW6126 Navajo White - Trim/Pop-Outs 3. SW9118 Tarnished Treasure- Trim/Pop-Outs 4. SW7515 Homestead Brown- Trim/Pop-Outs	Scheme #14 1. SW6357 Choice Cream - Body 2. SW6165 Connected Gray- Trim/Pop-Outs 3. SW7536 Bittersweet Stem- Trim/Pop-Outs 4. SW6117 Smokey Topaz - Trim/Pop-Outs	Scheme #23 1. SW6151 Quiver Tan - Body 2. SW6034 Dark Auburn – Trim/Pop-outs 3. SW6150 Universal Khaki- Trim/Pop-outs 4. SW7568 Neutral Ground- Trim/Pop-outs
Scheme #6 1. SW7036 Accessible Beige - Body 2. SW7013 Ivory Lace - Trim/Pop-Outs 3. SW6151 Quiver Tan - Trim/Pop-Outs 4. SW6068 Brevity Brown - Trim/Pop-Outs	Scheme #15 1. SW7553 Fragile Beauty - Body 2. SW7103 Whitetail - Trim/Pop-Outs 3. SW7744 Zeus - Trim/Pop-Outs 4. SW7055 Enduring Bronze - Trim/Pop-Outs	Scheme #24 1. SW2823 Rookwood Clay - Body 2. SW7719 Fresco Cream - Trim/Pop-outs 3. SW2822 Downing Sand– Trim/Pop-outs 4. SW7705 Wheat Penny- Trim/Pop-outs
Scheme #7 1. SW7534 Outerbanks - Body 2. SW7046 Anonymous - Trim/Pop-Outs 3. SW7555 Patience - Trim/Pop-Outs 4. SW6154 Nacre - Trim/Pop-Outs	Scheme #16 1. SW7519 Mexican Sand - Body 2. SW7596 Only Natural - Trim/Pop-Outs 3. SW7104 Cotton White - Trim/Pop-Outs 4. SW7523 Burnished Brandy- Trim/Pop-Outs	Scheme #25 1. SW7637 Oyster White - Body 2. SW0049 Silver Gray -Trim/Pop-outs 3. SW9171 Felted Wool -Trim/Pop-outs 4. SW7061 Night Owl -Trim/Pop-outs
Scheme #8 1. SW6122 Camelback - Body 2. SW6110 Steady Brown - Trim/Pop-Outs 3. SW7573 Eaglet Beige - Trim/Pop-Outs 4. SW2820 Downing Earth - Trim/Pop-Outs	Scheme #17 1. SW7562 Roman Column - Body 2. SW6006 Black Bean - Trim/Pop-outs 3. SW7505 Manor House- Trim/Pop-outs 4. SW 7047 Porpoise - Trim/Pop-outs	Scheme #26 1. SW7596 Only Natural - Body 2. SW7001 Marshmallow - Trim/Pop-outs 3. SW6080 Utterly Beige - Trim/Pop-outs 4. SW6053 Reddened Earth - Trim/Pop-outs
Scheme #9 1. SW7016 Mindful Gray - Body 2. SW7006 Extra White - Trim/Pop-Outs 3. SW6039 Poised Taupe - Trim/Pop-Outs 4. SW9160 Armadillo - Trim/Pop-Outs	Scheme #18 1. SW7103 Whitetail - Body 2. SW 7675 Sealskin - Trim/Pop-outs 3. SW9084 Cocoa Whip - Trim/Pop-outs 4. SW 9085 Touch of Sand Trim/Pop-outs	



COMMUNITY ASSOCIATION
Solar Energy Device Guidelines

- I. Application**
 - a. These Guidelines apply to solar panels and other solar energy devices governed by ARS 33-1816 and 44-1761.
 - b. Prior to installing any solar energy device, Owners shall submit to the ARC the “Application for Placement of Solar Energy Device” form attached to these Guidelines. A diagram/layout/rendering of exactly where the panels and equipment will be placed is also required.
- II.** No solar energy device (panels) may encroach upon the Common Area or the property of another Owner.
- III.** Solar energy devices (panels) must comply with all applicable Town, Country and State laws, regulations, and codes.
- IV.** The Owner is responsible for all costs associated with the installation and maintenance of the solar energy device (panels).
- V.** The Owner is responsible for all damage caused by or connected with the solar energy device (panels).
- VI.** The Owner must hold the Association harmless and indemnify the Association in the event that someone is injured by the solar energy device (panels).
- VII.** The Owner shall keep the solar energy device (panels) in good repair so that it does not violate any portion of these Guidelines.
- VIII.** All conduit, wiring, exterior of panel boxes, etc. must be painted to match the exterior colors of the body/trim/pop out/roof color to match existing.
- IX. Enforcement**
 - a. These Guidelines shall not be enforced in a way that (1) prevents the installation of solar energy devices; (2) impairs the functioning of the solar energy devices; (3) restricts the use of a solar energy device; or (4) adversely affects the cost or efficiency of the solar energy device.
- X. Rules Regarding Placement, Installation, and Maintenance**
 - a. Solar energy devices (panels) must be shielded from view from the street, Common Area, and neighboring properties, so as not to be Visible from Neighboring Property to the maximum extent possible. The landscaping or structure used to shield the solar energy device must be approved in advance by the ARC.
 - b. Placement and installation must be pursuant to the manufacturer’s instructions.
 - c. In order to protect against personal injury and property damage, the solar energy device must be properly grounded and secured. Also, it may not be placed in a location where it will come in contact with a power line or block or obstruct any driver’s view of an intersection or street.
 - d. When installing a solar energy device (panels), the Owner needs to take into consideration the provisions of its governing documents.

Revised 8-2023



COMMUNITY ASSOCIATION

Application for Placement of Solar Energy Device (panels)

For Islands Use Only

Date received in office:

Initials:

Account #: _____

Please return completed forms to the onsite office; you may drop them off, mail, or email.

Onsite office hours are Monday-Friday from 8am-5pm. 825 S. Islands Dr. W., Gilbert, AZ 85233

Phone: 480-545-7740

Email: islands.compliance@fsresidential.com

Date: _____ Owner's Name: _____

Islands Address: _____

Phone Number: _____ Email: _____

Sub Association (if you pay two assessments): _____

Charter Point, Coral Reef, Costain, Laguna Shores, Paradise Cove, Sandcastle, Seawynnds and The Falls must have Sub Association approval prior to submitting to The Islands. Please include your approval letter from your sub association.

Type of Device: _____ Company installing: _____

Identify Placement Location: *(as indicated in the guidelines, a diagram/layout/rendering of exactly where the panels and equipment will be placed is also required.)*

Roof (Front) Roof (Back) Roof (Side) Patio/Deck/Yard (Front) Patio/Deck/Yard (Back)

Other Specify: _____

Will the solar energy devices be placed so as to be *Visible from Neighboring Property*? Yes No

If Yes, please provide information or an explanation supporting the necessity for placement so as to be *Visible from Neighboring Property*.

Will the placement be in compliance with all Association guidelines (which include manufacturer's guidelines and applicable building codes)? Yes No

I will comply with all of the Association's Rules Regarding Placement, Installation, and Maintenance of solar energy devices. I assume liability for any damage to Association and other owner's property that occurs due to solar energy device placement, installation, and maintenance.

Signature of Owner

Date

For Architectural Review Committee Purposes Only

Date _____

ARC Approved _____

ARC Disapproved _____

ARC Approved; subject to the following conditions: _____

Approved by Administration _____

**THE ISLANDS COMMUNITY ASSOCIATION
BOARD OF DIRECTORS RESOLUTION
VIOLATION AND ENFORCEMENT POLICY**

Based on the power granted to the Board of Directors, the Board enacts the following Violation and Enforcement Policy. This policy supersedes all previous policies.

ENFORCEMENT OPTIONS

For violations of the governing documents, the Board has the following enforcement options:

1. Suspend the Owner's right to vote;
2. Suspend the Owner's right to use the Common Area;
3. File a lawsuit in Maricopa Superior Court in order to seek an injunction to compel compliance with the governing documents. In any such action, the Association shall be entitled to recover all costs, including but not limited to, attorneys fees and court costs incurred by the Association;
4. Exercise self-help; or
5. Impose fines against the Owner.

The Board has the option to choose any of the above options or a combination of options. If the Board decides to impose a fine, the Board may choose to follow the Fine Schedule below. Additionally, the Board or manager may turn over any violations to the Association's attorney at any time.

FINE SCHEDULE

The fines set forth in this Fine Schedule shall constitute damages sustained by the Association and are intended to compensate the Association for the administrative burden of addressing the violation and the adverse impact of the violation on the community.

The Board of Directors reserves the right to deviate from the fine amounts set forth herein. The Board also reserves the right to pursue any and all other remedies set forth in the Declaration at the same time or in lieu of levying the fines set forth in this Fine Schedule.

I. GENERAL FINE SCHEDULE

Typically, the amount of the fines imposed by the Board will be determined based on the following General Fine Schedule. Notwithstanding anything herein to the contrary, the Board retains the discretion to adopt supplemental fine schedules to address specific violations of the Association's governing documents and any such supplemental fine schedules may be set forth as exhibits to this Resolution. If a supplemental violation-specific schedule is not adopted, the General Fine Schedule will generally apply.

- A. COURTESY NOTICE:** The Board may, but is not required to, send a courtesy notice.
- B. TYPICAL FINE:** Typically, the first fine for a violation will be **\$50.00**.

- C. If the violation is not cured within the time period set forth by the Association or if the violation re-occurs within three (3) months, the second fine will typically be **\$75.00**.
- D. **CONTINUING OR REOCCURRING VIOLATIONS:** If the violation continues without resolution, a **fine of \$100.00** may be assessed **every 14 days** until the violation is resolved or every time a violation reoccurs within a three-month period.

II. SUPPLEMENTAL FINE SCHEDULES

Violation-specific fine schedules, if adopted by the Board, shall be set forth as Exhibits to this Resolution.

III. ADDITIONAL REMEDIES

- A. In addition to fines, the Board reserves the right to enforce violations by any other means allowed by the governing documents or applicable law.
- B. At any time, the Board or manager may turn over a matter to legal counsel for action, included but not limited to, a suit for injunctive relief.

The Board of Directors adopted the foregoing Resolution on NOV 28, 2022.

By:

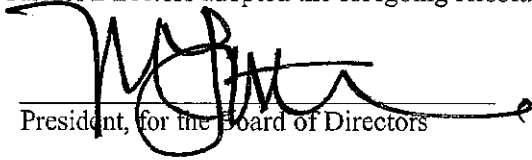

President, for the Board of Directors

EXHIBIT A

**SUPPLEMENTAL FINE SCHEDULE – VIOLATIONS RELATING TO BUILDING
WITHOUT ARCHITECTURAL REVIEW COMMITTEE WRITTEN APPROVAL**

The following Supplemental Fine Schedule shall apply when an Owner constructs without written approval from the Architectural Review Committee.

1. If an Owner constructs without written approval from the Architectural Review Committee, the Board may levy a fine of \$500.00.
2. If an Owner does not remedy the violation within the amount of time specified by the Association, the Board may levy a fine of \$100.00 every day until the violation is resolved.
3. The Board reserves the right to deviate from the fine amounts set forth herein. The Board also reserves the right to pursue any and all other remedies, including but not limited to the right to take legal action and all other remedies set forth in the Declaration, at the same time or in lieu of levying the fines set forth in this Supplemental Fine Schedule.

EXHIBIT B

SUPPLEMENTAL FINE SCHEDULE – VIOLATIONS RELATING TO SHORT-TERM RENTALS

The following Supplemental Fine Schedule shall apply to violations relating to Short-Term Rentals.

1. **COURTESY NOTICE:** The Board may, but is not required to, send a courtesy notice.
2. **FIRST VIOLATION:** If an Owner violates the Short-Term Rental policy, the Board may levy a fine of \$500.00 for the first violation.
3. **SECOND VIOLATION:** If an Owner violates the Short-Term Rental policy a second time within 6 months after the first violation, the Board may levy a fine of \$1,000.00 for the second violation.
4. **THIRD VIOLATION:** If an Owner violates the Short-Term Rental policy a third time within 6 months after the second violation, the Board may levy a fine of \$1,500.00 for the third violation.
5. For any violation after that, the Board will determine the fine on a case-by-case basis.
6. The Board reserves the right to deviate from the fine amounts set forth herein. The Board also reserves the right to pursue any and all other remedies, including but not limited to the right to take legal action and all other remedies set forth in the Declaration, at the same time or in lieu of levying the fines set forth in this Supplemental Fine Schedule.